



Switchgear Types 8DJ20 and 8DH10 up to 24 kV, Gas-Insulated, Circuit-Breaker Feeders up to 630 A, Type LST

Medium-Voltage Switchgear

Supplements to Catalogs HA 45.31/41.11 · 2008

Answers for energy.

SIEMENS

Contents

Application, Requirements	Pages
Features, typical uses	2 and 3
Technical Data	
Electrical data, filling pressure, temperature for switchgear type 8DJ20 and type 8DH10	4 to 6
Product Range	
Common equipment features	7
Product range overview, schemes, front views, floor openings, transport data	8 to 15
Design	
Panel design	16
Components	
Disconnecting circuit-breaker	17
Installation of current transformers in 8DJ20 switchgear	18
Installation of current transformers in 8DH10 switchgear	19
Cable connections	20 to 23
Protection system	24
Shipping	
Transport data for 8DJ20 switchgear	25
Standards	
Standards, specifications, guidelines	26
Notes	
	26
Further information	
See the following catalogs:	
• HA 40.1 (Switchgear 8DJ and 8DH, General Part)	
• HA 41.11 (Switchgear 8DH10)	
• HA 45.31 (Switchgear 8DJ20)	



The products and systems described in this catalog are manufactured and sold according to a certified quality and environmental management system (acc. to ISO 9001 and ISO 14001).
 (DQS Certificate Reg. No. DQS 003473 QM UM).
 The certificate is accepted in all IQNet countries.

Application

Features

8DJ20

8DJ20 switchgear is a gas-insulated, factory-assembled, type-tested and metal-enclosed switchgear for indoor installation.

It is available as a non-extendable, block-type construction consisting of panel blocks:

- Up to 24 kV
- Feeder currents up to 630 A

8DH10

8DH10 switchgear is a gas-insulated, factory-assembled, type-tested, 3-pole and metal-enclosed switchgear for indoor installation.

It is designed as a single-busbar switchgear. Due to its extendable design, various panel/ switchgear combinations are available:

- Up to 24 kV
- Feeder currents up to 630 A
- Busbar currents up to 1250 A

Technology

- Maintenance-free
- Climate-independent
- Partition class: PM (partition of metal)
- Three-pole primary enclosure, metal-enclosed
- Insulating and quenching gas SF₆
- Gas-tight, welded switchgear vessel made of stainless steel, with welded-in bushings for electrical connections and mechanical components
- Cable connection for bushings with outside cone according to EN 50 181
- Easy installation

Quality and environment

Quality and environmental management system according to DIN EN ISO 9001 and DIN EN ISO 14001

Application

Typical uses

The product range comprises the following additions:

Switchgear type 8DJ20

8DJ20 switchgear can be designed as switchgear consisting of ring-main feeders (RK) and circuit-breaker feeders (LST) as follows (for details refer to page 8).

Schemes:

- 10-LST: 2 RK and 1 LST
- 71-LST: 3 RK and 1 LST
- 20-LST: 1 RK and 1 LST
- 21-LST: 1 K (E) and 1 LST

Three overall heights can be selected:

- 1200 mm
- 1400 mm (standard)
- 1760 mm

Switchgear type 8DH10

Including the circuit-breaker feeder type LST, the following product range is now available for 8DH10 switchgear:

- Individual panels up to 24 kV
 - Circuit-breaker panel type LST1
- Panel blocks up to 24 kV
 - Types (for details refer to page 11):
 - R LST-B2: 700 mm wide
 - 2R LST-B3: 1050 mm wide
 - 3R LST-B4: 1400 mm wide
 - K LST-B2: 700 mm wide

Typical uses

The feeder with the disconnecting circuit-breaker completes the existing applications and typical uses of 8DJ20 and 8DH10 switchgear.

With this product range there are additional switchgear types with cost-efficient standard protection systems available for power distribution in secondary distribution systems – which can also be used under adverse environmental conditions – such as:

- Compact substations and transformer substations, e.g. for wind power stations
- Substations, customer transfer substations and switching substations of power supply companies
- Industrial plants, such as:
 - Wind power stations
 - High-rise buildings
 - Airports
 - Underground railway stations, etc.



8DJ20 switchgear
Scheme 10-LST



Example:
Customer transfer switchgear 8DH10

Application:
Power supply of high-rise buildings

Technical Data

Electrical data for 8DJ20

Filling pressure, temperature

8DJ20 switchgear with circuit-breaker feeders type LST²⁾

Rated voltage U_r		kV	7.2	12	15	17.5 ^{o)}	24	
Rated insulation level	Rated short-duration power-frequency withstand voltage U_d :							
	– phase-to-phase, phase-to-earth, open contact gap	kV	20	28 ³⁾	36	38 ^{o)}	50	
	– across isolating distance	kV	23	32 ³⁾	39	45	60	
Rated lightning impulse withstand voltage U_p :	– phase-to-phase, phase-to-earth, open contact gap	kV	60	75 ³⁾	95	95	125	
	– across isolating distance	kV	70	85 ³⁾	110	110	145	
Rated frequency f_r		Hz	50	50	50	50	50	
Rated normal current I_r ¹⁾	for feeders	up to A	250 or 630					→
	for busbar	up to A	630	630	630	630	630	
Rated short-time withstand current I_k	for switchgear with $t_k = 1$ s	up to kA	16	20	16	20	16	20
	for switchgear with $t_k = 3$ s	up to kA	–	20	–	20	16	20

Disconnecting circuit-breaker (type LST) (circuit-breaker with disconnecting function as three-position switch with earthing function)

Rated voltage U_r		kV	7.2	12	15	17.5	24	
Rated insulation level	Rated short-duration power-frequency withstand voltage U_d	kV	20	28	36	38	50	
	Rated lightning impulse withstand voltage U_p	kV	60	75	95	95	125	
Rated frequency f_r		Hz	50	50	50	50	50	
Rated normal current I_r ¹⁾	for feeders (type LST)	A	250 or 630					→
Rated short-time withstand current I_k	for switchgear with $t_k = 1$ s	up to kA	16	20	16	20	16	20
	for switchgear with $t_k = 3$ s	up to kA	–	20	–	20	16	20
Rated peak withstand current I_p		up to kA	40	50	40	50	40	50
Rated short-circuit making current I_{ma}		up to kA	40	50	40	50	40	50
Rated short-circuit breaking current I_{SC} [*]		up to kA	16	20	16	20	16	20
Rated cable-charging breaking current I_C		A	63	63	63	63	63	
Classes and number of operating cycles (function, standards):								
Number of electrical operating cycles "n" for circuit-breaker at:	Rated normal current I_r	n	2000					→
	Rated short-circuit making current I_{ma} [*]	n	4	4	4	4	4	–
	Rated short-circuit breaking current I_{SC} Standard [*] Option	n	6	6	6	6	6	–
		n	20	–	20	–	20	–
			Class E2 (IEC 62 271-100)					→
Number of mechanical operating cycles "n" for circuit-breaker		n	2000, Class M1 (IEC 62 271-100)					→
Number of mechanical operating cycles "n" for disconnecter function		n	2000, Class M1 (IEC 62 271-102)					→
Number of mechanical operating cycles "n" for make-proof earthing switch ^{***)}		n	1000 (IEC 62 271-102)					→
Number of electrical operating cycles "n" for earthing switch ^{***)} at rated short-circuit making current I_{ma}		n	5, Class E2 (IEC 62 271-102)					→
Classification "C" for circuit-breaker: Low probability of restrikes for capacitive currents			Class C1 (IEC 62 271-100)					→
Rated operating sequence (IEC 62 271-100) [*]			O-t-CO-t'-CO, $t = t' = 3$ min, i.e.: O-3 min-CO-3 min-CO					

Make-proof earthing switch, earthing function of the three-position switch

Rated voltage U_r		kV	7.2	12	15	17.5	24
Rated short-circuit making current I_{ma}		up to kA	40	50	40	50	40
Rated short-time withstand current (1 s) I_k		up to kA	16	20	16	20	16

Pressure values at 20 °C for switchgear up to 12 kV

Rated filling level p_{re} for insulation	1750 hPa (absolute)
Minimum functional level p_{me} for insulation	1550 hPa (absolute)

Pressure values at 20 °C for switchgear > 12 kV

Rated filling level p_{re} for insulation	1950 hPa (absolute)
Minimum functional level p_{me} for insulation	1750 hPa (absolute)

Ambient air temperature T ^{**)} Δ)

Switchgear and/or feeders with secondary equipment	Class "Minus 5 indoor" (– 5 °C to +55 °C) ΔΔ)
Switchgear and/or feeders with secondary equipment Δ)	Class "Minus 25 indoor" (– 25 °C to +55 °C) ΔΔ)

Classification

Partition class (partition of metal)	PM
Loss of service continuity category	LSC 2B

Note:

For further electrical data for switching devices, refer to Catalog HA 40.1, general part for 8DJ and 8DH switchgear.

1) The rated normal currents apply to ambient air temperatures of max. 40 °C. The 24-hour-mean is max. 35 °C (according to IEC 62 271-1 / VDE 0671-1).

2) Higher values on request.

3) Option: $U_d = 42$ kV, $U_p = 95$ kV, according to some national requirements.

^{*}) According to IEC 62 271-100, T100s.

^{**)} Operating conditions according to IEC 62 271-1 / VDE 0671-1. The ambient air temperature depends on the protection relays or low-voltage devices installed.

^{***)} Terms: See page 26.

Δ) Please observe the operating conditions of the additional secondary equipment/low-voltage devices used.

ΔΔ) Temperature range, reduced normal currents at > + 40 °C.

o) Data for Russian Federation
– Rated voltage 12 kV
– Rated short-duration power frequency withstand voltage 42 kV.

Three-position switch-disconnector in ring-main feeders

		kV	7.2	12	15	17.5	24	
Rated insulation level	Rated voltage U_r	kV	7.2	12	15	17.5	24	
	Rated short-duration power-frequency withstand voltage U_d	kV	20	28	36	38	50	
	Rated lightning impulse withstand voltage U_p	kV	60	75	95	95	125	
Rated frequency f_r		Hz	50	50	50	50	50	
Rated normal current I_r ¹⁾	for feeders (type RK.. or type K..)	A	400 or 630					
Rated short-time withstand current I_k	for switchgear with $t_k = 1$ s	up to kA	16	20	16	20	16	20
	for switchgear with $t_k = 3$ s	up to kA	16	20	16	20	16	20
Rated peak withstand current I_p		up to kA	40	50	40	50	40	50
Rated short-circuit making current I_{ma}		up to kA	40	50	40	50	40	50
Class and number of operating cycles (function, standards):								
Number of electrical operating cycles "n" for switch-disconnector at:	Rated normal current I_r	n	100					
	Rated short-circuit making current I_{ma}	n	5	5	5	5	5	
		Class	E3 (IEC 60 265-1)					
Number of mechanical operating cycles "n" for circuit-breaker		n	1000, Class M1 (IEC 60 265-1)					
Number of mechanical operating cycles "n" for disconnector function		n	1000, Class M0 (IEC 62 271-102)					

Make-proof earthing switch

		kV	7.2	12	15	17.5	24	
Rated insulation level	Rated voltage U_r	kV	7.2	12	15	17.5	24	
	Rated short-duration power-frequency withstand voltage U_d	kV	20	28	36	38	50	
	Rated lightning impulse withstand voltage U_p	kV	60	75	95	95	125	
Rated short-time withstand current I_k	for switchgear with $t_k = 1$ s	up to kA	16	20	16	20	16	20
	for switchgear with $t_k = 3$ s	up to kA	16	20	16	20	16	20
Rated peak withstand current I_p		up to kA	40	50	40	50	40	50
Rated short-circuit making current I_{ma}		up to kA	40	50	40	50	40	50
Class and number of operating cycles (function, standards):								
– Number of electrical operating cycles "n" for earthing switch ^{*)} at rated short-circuit making current I_{ma}		n	5, Class E2 (IEC 62 271-102)					
– Number of mechanical operating cycles "n" for make-proof earthing switch ^{*)}		n	1000 (IEC 62 271-102)					

Switching capacity of general-purpose switches (class E3)

		kV	7.2	12	15	17.5	24
Rated voltage U_r		kV	7.2	12	15	17.5	24
Test duty 1	Rated mainly active load break current I_r for 100 switching operations	A	630	630	630	630	630
	for 20 switching operations	A	31.5	31.5	31.5	31.5	31.5
Test duty 2a	Rated closed-loop breaking current I_{2a}	A	630	630	630	630	630
Test duty 3	Rated transformer breaking current I_3	A	40	40	40	40	40
Test duty 4a	Rated cable-charging breaking current I_{4a}	A	68	68	68	68	68
Test duty 4b	Rated line-charging breaking current I_{4b}	A	68	68	68	68	68
Test duty 5	Rated short-circuit making current I_{ma}	up to kA	63	63	63	63	50
Test duty 6a	Rated earth-fault breaking current I_{6a} (I_e) ²⁾	A	60	60	60	60	60
Test duty 6b	Rated cable-charging breaking current and line-charging breaking current under earth-fault conditions I_{6b} ($\sqrt{3} \cdot I_{CL}$) ²⁾	A	35	35	35	35	35
–	Cable-charging breaking current under earth-fault conditions with superimposed load current $I_L + \sqrt{3} \cdot I_{CL}$	A	630+50	630+50	630+50	630+50	630+50

Note:

For further electrical data for switching devices, refer to Catalog HA 40.1, general part for 8DJ and 8DH switchgear.

1) The rated normal currents apply to ambient air temperatures of max. 40 °C. The 24-hour-mean is max. 35 °C (according to IEC 62 271-1 / VDE 0671-1).

2) Data in brackets according to existing standards.

*) Terms: See page 26.

Technical Data

Electrical data for 8DH10

Filling pressure, temperature

8DH10 switchgear in combination with circuit-breaker panels type LST²⁾⁴⁾

Rated insulation level	Rated voltage U_r	kV	7.2	12	15	17.5 ^{o)}	24	
	Rated short-duration power-frequency withstand voltage U_d :	– phase-to-phase, phase-to-earth, open contact gap	kV	20	28 ³⁾	36	38 ^{o)}	50
		– across isolating distance	kV	23	32 ³⁾	39	45	60
Rated lightning impulse withstand voltage U_p :	– phase-to-phase, phase-to-earth, open contact gap	kV	60	75 ³⁾	95	95	125	
	– across isolating distance	kV	70	85 ³⁾	110	110	145	
Rated frequency f_r		Hz	50	50	50	50	50	
Rated normal current I_r ¹⁾ for busbar	Standard	up to A	630	630	630	630	630	
	Option	up to A	1250	1250	1250	1250	1250	
Rated short-time withstand current I_k	for switchgear with $t_k = 1$ s	up to kA	16 20	16 20	16 –	16 –	16 –	
	for switchgear with $t_k = 3$ s	up to kA	– –	– 20	– –	– –	– –	

Circuit-breaker panel type LST/LST1⁵⁾

Rated insulation level	Rated voltage U_r	kV	7.2	12	15	17.5	24
	Rated frequency f_r	Hz	50	50	50	50	50
Rated normal current I_r ¹⁾	for feeder	up to A	250	250	250	250	250
	Option	up to A	630	630	630	630	630
Rated short-time withstand current I_k	for switchgear with $t_k = 1$ s	up to kA	16 20	16 20	16 –	16 –	16 –
	for switchgear with $t_k = 3$ s	up to kA	– –	– 20	– –	– –	– –
Rated peak withstand current I_p		up to kA	40 50	40 50	40 –	40 –	40 –

Disconnecting circuit-breaker (type LST)

(circuit-breaker with disconnecting function as three-position switch with earthing function)

Rated insulation level	Rated voltage U_r	kV	7.2	12	15	17.5	24
	Rated short-duration power-frequency withstand voltage U_d	kV	20	28	36	38	50
	Rated lightning impulse withstand voltage U_p	kV	60	75	95	95	125
Rated frequency f_r		Hz	50	50	50	50	50
Rated normal current I_r ¹⁾	for feeders (type LST)	A	250 or 630	→			
Rated short-time withstand current I_k	for switchgear with $t_k = 1$ s	up to kA	16 20	16 20	16 –	16 –	16 –
	for switchgear with $t_k = 3$ s	up to kA	– –	– 20	– –	– ⁵⁾ – ⁵⁾	–
Rated peak withstand current I_p		up to kA	40 50	40 50	40 –	40 –	40 –
Rated short-circuit making current I_{ma}		up to kA	40 50	40 50	40 –	40 –	40 –
Rated short-circuit breaking current I_{SC} [*]		up to kA	16 20	16 20	16 –	16 –	16 –
Rated cable-charging breaking current I_C		A	63	63	63	63	63
Classes and number of operating cycles (function, standards):							
Number of electrical operating cycles "n" for circuit-breaker at:	Rated normal current I_r	n	2000	→			
	Rated short-circuit making current I_{ma} [*]	n	4 4	4 4	4 –	4 –	4 –
	Rated short-circuit breaking current I_{SC} [*]	n	6 6	6 6	6 –	6 –	6 –
	Standard [*]	n	20	–	20	–	20
	Option	n	20	–	20	–	20
Class E2 (IEC 62 271-100) →							
Number of mechanical operating cycles "n" for circuit-breaker		n	2000, Class M1 (IEC 62 271-100)	→			
Number of mechanical operating cycles "n" for disconnecter function		n	2000, Class M1 (IEC 62 271-102)	→			
Number of mechanical operating cycles "n" for make-proof earthing switch ^{***)}		n	1000 (IEC 62 271-102)	→			
Number of electrical operating cycles "n" for earthing switch ^{***)} at rated short-circuit making current I_{ma}		n	5, Class E2 (IEC 62 271-102)	→			
Classification "C" for circuit-breaker: Low probability of restrikes for capacitive currents			Class C1 (IEC 62 271-100)	→			
Rated operating sequence (IEC 62 271-100) [*]			O-t-CO-t'-CO, t = t' = 3 min, i.e.: O-3 min-CO-3 min-CO				

Make-proof earthing switch, earthing function of the three-position switch

Rated voltage U_r	kV	7.2	12	15	17.5	24
Rated short-circuit making current I_{ma}	up to kA	40 50	40 50	40 –	40 –	40 –
Rated short-time withstand current (1 s) I_k	up to kA	16 20	16 20	16 –	16 –	16 –

Pressure values at 20 °C for panels LST ...⁵⁾ up to 12 kV

Rated filling level p_{re} for insulation	1750 hPa (absolute)
Minimum functional level p_{me} for insulation	1550 hPa (absolute)

Pressure values at 20 °C for panels LST ...⁵⁾ > 12 kV

Rated filling level p_{re} for insulation	1950 hPa (absolute)
Minimum functional level p_{me} for insulation	1750 hPa (absolute)

Ambient air temperature $T^{**)$ Δ)

Switchgear and/or feeders with secondary equipment	Class "Minus 5 indoor" (– 5 °C to +55 °C) ΔΔ)
Switchgear and/or feeders with secondary equipment Δ)	Class "Minus 25 indoor" (– 25 °C to +55 °C) ΔΔ)

Classification

Partition class (partition of metal)	PM
Loss of service continuity category	LSC 2B

Note:

For further electrical data for switching devices, refer to Catalog HA 40.1, general part for 8DJ and 8DH switchgear.

1) The rated normal currents apply to ambient air temperatures of max. 40 °C. The 24-hour-mean is max. 35 °C (according to IEC 62 271-1 / VDE 0671-1).

2) Higher values on request.

3) Option: $U_d = 42$ kV, $U_p = 95$ kV, according to some national requirements.

4) For three-position switch-disconnectors, see page 5 and Catalog HA 40.1.

5) As individual panel type LST1. As feeder type LST in panel blocks.

^{*}) According to IEC 62 271-100, T100s.

^{**)} Operating conditions according to IEC 62 271-1 / VDE 0671-1. The ambient air temperature depends on the protection relays or low-voltage devices installed.

^{***)} Terms: See page 26.

Δ) Please observe the operating conditions of the additional secondary equipment/ low-voltage devices used.

ΔΔ) Temperature range, reduced normal currents at > + 40 °C.

o) Data for Russian Federation – Rated voltage 12 kV – Rated short-duration power frequency withstand voltage 42 kV.

Product Range

Common equipment features

Feeders, panel		8DJ20		8DH10		8DH10	
Serial no.	Panel as:	Feeder in panel blocks, panel width = 350 mm		Feeder type LST1 as individual panel, panel width = 500 mm		Feeder type LST in panel blocks, panel width = 350 mm	
		Cable feeder LST	o. r. transfer LST-U	Cable feeder LST1	o. r. transfer LST1-U	Cable feeder LST	Transfer LST-U
1	Interlock of cable compartment cover	●	●	●	–	●	●
2	C-rail for cable bracket	●	–	●	–	●	–
3	Low-voltage niche for terminals and protection device above operating mechan. box	●	●	●	–	●	●
4	Low-voltage terminals in operating mechanism box	●	●	●	–	●	●
5	Mechanical ready-for-service indicator for disconnecting circuit-breaker/three-position switch	●	●	●	–	●	●
6	Signalling switch (1NO) for remote electrical ready-for-service indication	○	○	○	–	○	○
7	Short-circuit and earth-fault indicator	○	○ ¹⁾	○	–	○	○ ¹⁾
8	Closing lock-out for the disconnecting circuit-breaker "CLOSED" function	○	○	○	–	○	○
8 a	de-earthing lock-out for the earthing switch in "EARTHED" position function	○	○	○	–	○	○
9	Low-voltage compartment (see pages 9 and 12)	○	○	○	–	○	○
10	Low-voltage cover	○	○	○	–	○	○
11 a	Cable clamps – Supplied separately	○	–	○	–	○	–
11 b	– Preassembled	○	–	○	–	○	–
12	Secondary equipment	○	○	○	–	○	○
13	Capacitive voltage detecting system for feeder	●	●	●	–	●	●
14	Capacitive voltage detecting system for busbar	–	–	○	–	○	○
15	Cable-type current transformer	○	–	○	–	○	–
16	Three-phase current transformer	–	–	○	–	–	–
17 a	Protection device Standard: Make Siemens, type 7SJ45 (c.t.-operated principle)	○	○	○	–	○	○
17 b	Option: Make Siemens, type 7SJ46 (for auxiliary voltage supply)	○	○	○	–	○	○
17 c	Option: Make SEG, type WIC-2P, -3P	○	○	○	–	○	○
18	Plug-in voltage transformer type 4MT8 at the feeder ²⁾	–	–	○	–	–	–

Equipment features of the disconnecting circuit-breaker (type LST) ³⁾	8DJ20	8DH10	8DH10
Equipment features	LST	LST1	LST
Manual operating mechanism for the disconnecting circuit-breaker	●	●	●
Motor operating mechanism for the disconnecting circuit-breaker CLOSED/OPEN			
– With "remote" operation (wired to terminals)	○	○	○
– With "local" operation via control switch	○	○	○
– With "local" operation via control switch and local-remote switch	○	○	○
Manual operating mechanism for the switching function "make-proof EARTHING"	●	●	●
Auxiliary switch in 8DJ20 switchgear (disconnecting circuit-breaker CLOSED/OPEN: 1 NO + 2 NC, EARTHING CLOSED/OPEN: 1 NO + 1 NC)	●	●	●
Auxiliary switch in 8DH10 switchgear (disconnecting circuit-breaker CLOSED/OPEN: 2 NO + 2 NC, EARTHING CLOSED/OPEN: 2 NO + 2 NC)	●	●	●
Wiring of disconnecting circuit-breaker: To terminal blocks, type VBST4-FS (optionally in the low-voltage niche or low-voltage compartment)	●	●	●
Locking device	○	○	○
Release designed as shunt release (f)	○	○	○
Release designed as c.t.-operated release (low-energy 0.1 Ws)	○	○	○
Mechanical switch position indicator	●	●	●
Separate operating levers for:			
– Disconnecting circuit-breaker	○	○	○
– Make-proof earthing switch	○	○	○
1) Only for short-circuit indicators with sensors on the bushings.	● Basic equipment		
2) Deep cable compartment cover necessary.	○ Additional equipment (option)		
3) Description and definition: See pages 17 and 26.	– Not available		
	o. r. = On request		

Product Range

Product range overview for 8DJ20: Schemes

Scheme: Components shown in dotted lines can be used optionally.
Standard

Scheme 20-LST

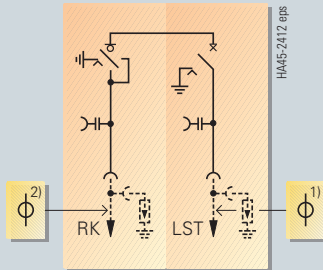

Scheme 21-LST

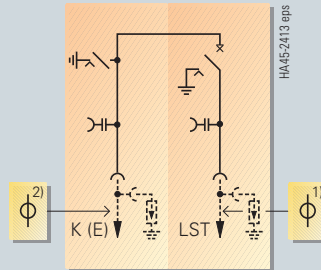

Scheme 10-LST

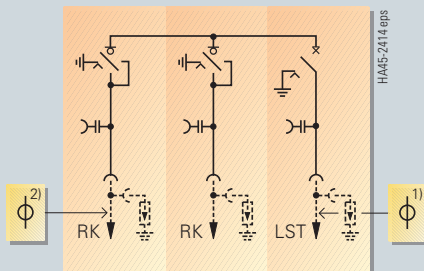

Scheme 71-LST

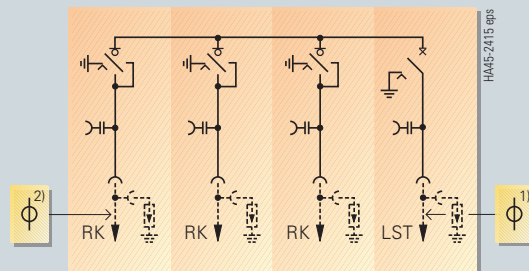

1) Cable-type current transformer type 4MC70 33

2) On request: Cable-type current transformer type 4MC70 31

Abbreviations:

RK = Ring-main feeder LST = Circuit-breaker feeder with disconnecting function

K = Cable feeder for radial cable connection (standard)

K(E) = Cable feeder for radial cable connection with make-proof earthing switch (option)

Product Range

Product range overview for 8DJ20: Front views, combinations

Front views
(Floor openings see page 10)
For explanation of the abbreviations RK, LST and K(E), see page 8.

Overall dimensions			Net weight ¹⁾ approx. kg
Width	Depth ²⁾	Height	
mm	mm	mm	
Scheme 20-LST			
1 ring-main feeder, 1 circuit-breaker feeder (Abbreviations 1RK+1LST)			
710	775	1200	350
		1400	370
		1760	400
Scheme 21-LST			
1 radial cable connection, 1 circuit-breaker feeder (Abbreviations 1K(E)+1LST)			
710	775	1200	350
		1400	370
		1760	400

Scheme 10-LST			
2 ring-main feeders, 1 circuit-breaker feeder (Abbreviations 2RK+1LST)			
1060	775	1200	450
		1400	480
		1760	510
Scheme 71-LST			
3 ring-main feeders, 1 circuit-breaker feeder (Abbreviations 3RK+1LST)			
1410	775	1200	540
		1400	580
		1760	620

1) Weight depending on the relevant equipment, e.g. motor operating mechanism, current transformers, etc.

2) Additional wall distance required: ≥ 15 mm

Combinations with low-voltage compartment
Dimensions e.g. for scheme 20-LST

For switchgear with low-voltage compartment other transport dimensions and weights must be observed.

Switchgear height

1200 mm 1400 mm 1760 mm

Product Range

Product range overview for 8DJ20: Floor openings

Floor openings (dimensions in red) and fixing points

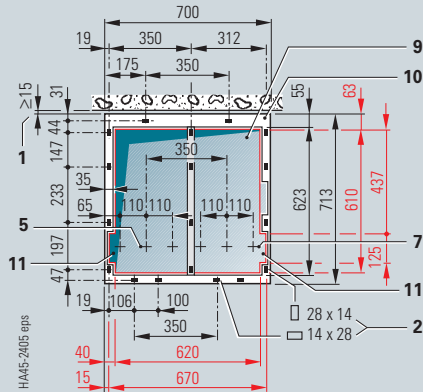

Scheme 20-LST

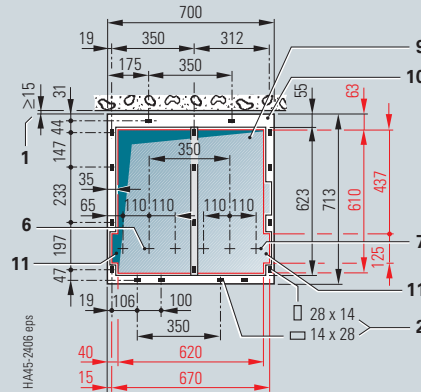

Scheme 21-LST

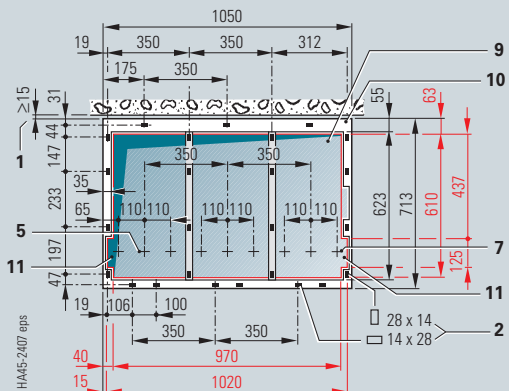

Scheme 10-LST

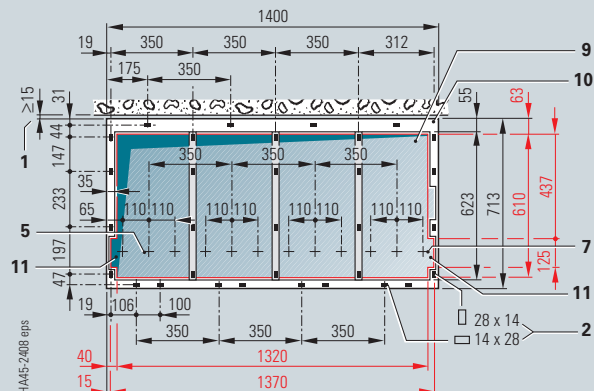

Scheme 71-LST

- | | |
|---|--|
| <ul style="list-style-type: none"> 1 Wall distance 2 Fixing points 5 Position of the incoming cables in the ring-main feeder 6 Position of the incoming cables in the cable feeder 7 Position of the incoming cables in the circuit-breaker feeder | <ul style="list-style-type: none"> 9 Floor opening for high-voltage cables (and control cables, if applicable) 10 Fixing frame (base) of the switchgear 11 Cutouts for 1200 mm and 1400 mm switchgear height, for cable-type current transformers |
|---|--|

Product Range

Product range overview for 8DH10

Circuit-breaker panel as individual panel type LST1

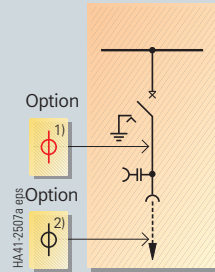

Type LST1
500 mm wide
Standard: Basic panel

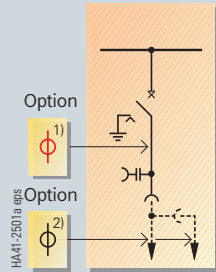

Type LST1
500 mm wide
Option: For 2nd cable

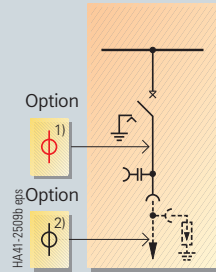

Type LST1
500 mm wide
Option:
For plug-in
surge arresters

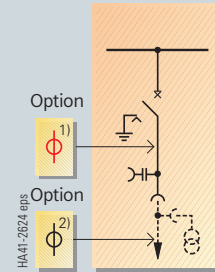

Type LST1
500 mm wide
Option: For plug-in
voltage transformers
type 4MT8 (deep cable
compartment cover: 300 mm)

Circuit-breaker feeder LST in panel blocks

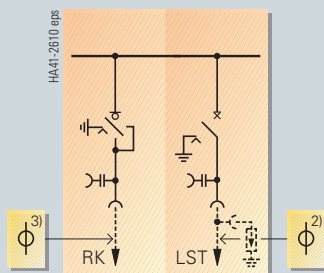

Type R LST-B2
700 mm wide

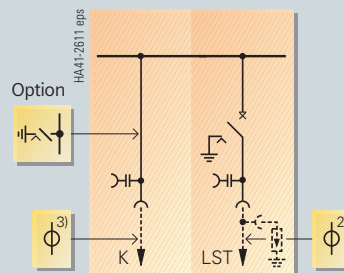

Type K LST-B2
700 mm wide

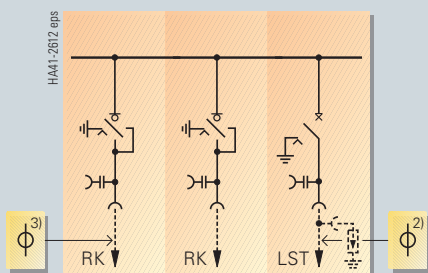

Type 2R LST-B3
1050 mm wide

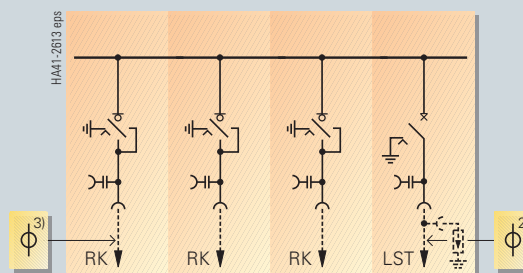

Type 3R LST-B4
1400 mm wide

Components shown in dotted lines can be used optionally.

Abbreviations:

RK = Ring-main feeder

LST = Circuit-breaker feeder with disconnecting function

K = Cable feeder

- 1) Three-phase current transformer type 4MC 63
- 2) Cable-type current transformer type 4MC 7033
- 3) Cable-type current transformer type 4MC 7031

Product Range

Product range overview for 8DH10: Front views

Front views

Individual panel

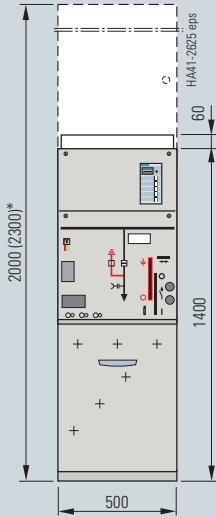

Individual panel LST1

Panel blocks

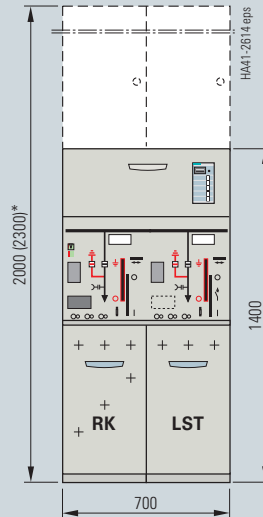

Type R LST-B2

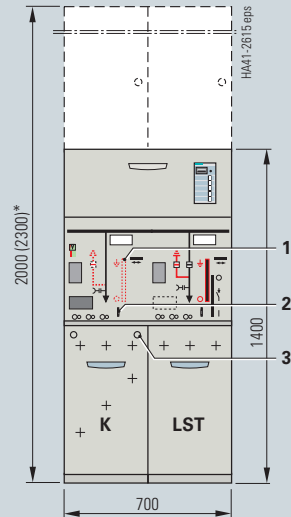

Type K LST-B2

Cable panel type K:

- 1 Option: Earthing function
- 2 Interlocking of the cable compartment cover in conjunction with earthing function
- 3 Cable compartment cover screwed on (without earthing function)

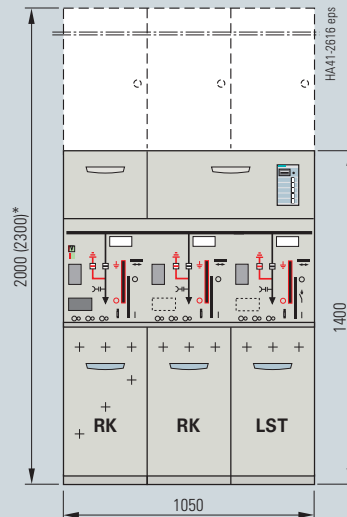

Type 2R LST-B3

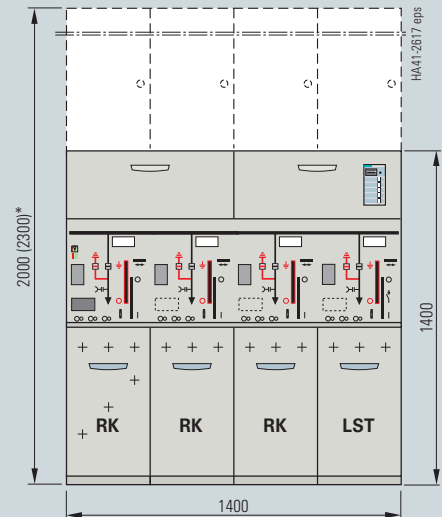

Type 3R LST-B4

Abbreviations:

RK = Ring-main feeder

LST = Circuit-breaker feeder with disconnecting function

K = Cable feeder

* Option: With low-voltage compartment

Product Range

Product range overview for 8DH10: Floor openings

Floor openings (dimensions in red) and fixing points

Individual panel type LST1

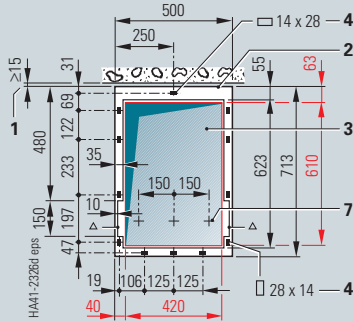

For circuit-breaker panel type LST1 without cable-type current transformers

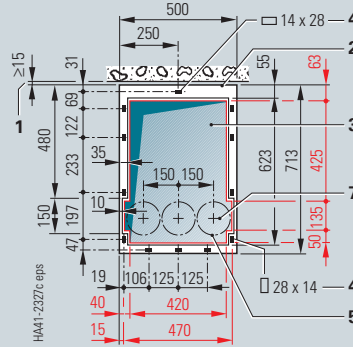

For circuit-breaker panel type LST1 with cable-type current transformers

Panel blocks

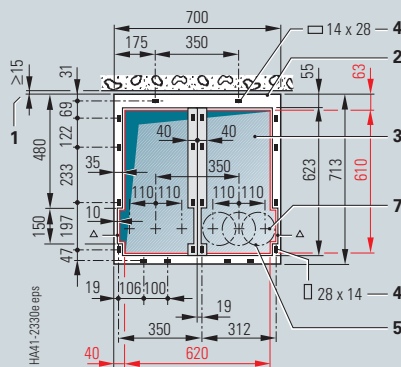

Type K LST, R LST-B2

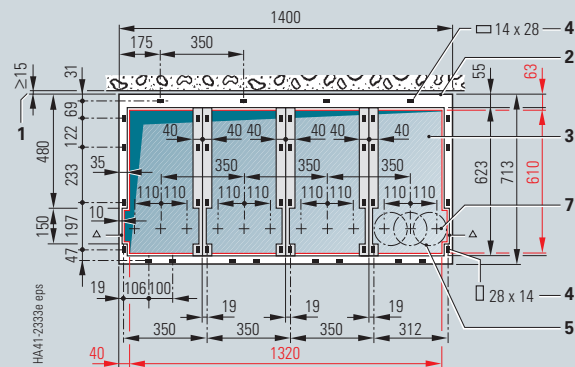

Type 3R LST-B4

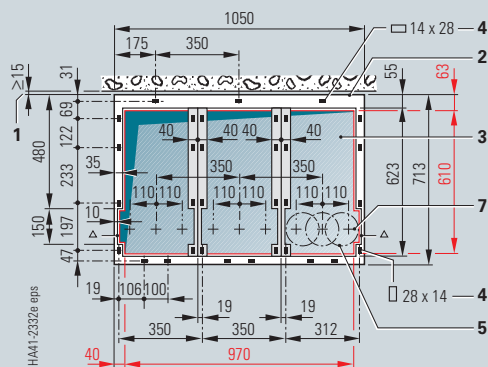

Type 2R LST-B3

- 1 Wall distance
- 2 Fixing frame (base) of an individual panel or panel block
- 3 Floor opening for high-voltage cables and control cables, if applicable
- 4 Fixing points
- 5 For 4MC70 33 cable-type current transformer with 145 mm outside diameter, sometimes arranged underneath the panel
- 7 Position of the incoming cables for the feeder

Product Range

Product range overview for 8DH10, transport data for 8DH10

Abbreviation: LST

Disconnecting circuit-breaker:
Circuit-breaker with disconnecting function and make-proof earthing switch as three-position switch.

Legend for page 15

△ = Three-position switch as three-position switch-disconnector (switch-disconnector CLOSED-OPEN-EARTHED).

△△ = Three-position switch as three-position disconnecting circuit-breaker (disconnecting circuit-breaker CLOSED-OPEN-EARTHED).

1) The equipment applies to the entire panel block, but it is located in the first feeder panel from the left.

2) Low-voltage terminals arranged in the low-voltage compartment (low-voltage compartment to be ordered optionally).

Designation of the individual panels and panel blocks	Panel width	Type
Individual panels		
Circuit-breaker panel LST1	500 500	LST1 On request: LST-U
Panel blocks		
Ring-main/circuit-breaker panel block	700 1050 1400	R LST-B2 < RK LST 2R LST-B3 < RK LST 3R LST-B4 < RK LST
Cable connection/circuit-breaker panel block (cable panel without make-proof earthing switch)	700	K LST-B2 < K LST
Cable connection/circuit-breaker panel block (cable panel with make-proof earthing switch)	700	K LST-B2 < K LST

Transport data (Transport units for shipping see page 15)

Individual panel, panel block or combinations thereof for standard switchgear (without pressure relief duct)	Type	Panel or panel combination		Transport unit (including packing) for standard panels (without pressure absorber system)				
		Width B1	Net weight ¹⁾	Width B2	Height	Depth T2	Volume	Gross weight ¹⁾
		mm	approx. kg	m	m	m	m ³	approx. kg
			without/with LVC */ LVC *		without/with LVC */ LVC *		without/with LVC */ LVC *	without/with LVC */ LVC *

1) The net weight and the gross weight depends on the extent to which they are equipped (e.g. with current transformers, motor operating mechanism, deep cable compartment cover) and are therefore given as mean value.

2) Sum of the net weights of individual panels and/or panel blocks.

* Low-voltage compartment, 600 mm high, weight approx. 60 kg depending on the panel type and on the extent to which it is equipped.

** Packing weight.

Transport of individual panels

Circuit-breaker panel	LST1	500	280 / 340	0.70	1.60 / 2.20	1.10	1.23 / 1.69	320 / 380
-----------------------	------	-----	-----------	------	-------------	------	-------------	-----------

Transport of panel blocks

Ring-main/circuit-breaker panel block	R LST-B2	700	400 / 520	1.08	1.60 / 2.20	1.10	1.90 / 2.61	460 / 580
	2R LST-B3	1050	510 / 690	1.40	1.60 / 2.20	1.10	2.46 / 3.40	580 / 760
	3R LST-B4	1400	610 / 850	2.03	1.60 / 2.20	1.10	3.57 / 4.91	690 / 930
Cable connection/circuit-breaker panel block	K LST-B2	700	400 / 520	1.08	1.60 / 2.20	1.10	1.90 / 2.61	460 / 580

Transport of combinations of different individual panels or panel blocks

Comprising	Overall width B3	B2	T2			
- a number of individual panels or	≤ 850 mm	1.08	1.60 / 2.20	1.10	1.90 / 2.61	2) + 60 **
- 1 panel block or	≤ 1200 mm	1.40	1.60 / 2.20	1.10	2.46 / 3.39	2) + 70 **
- a number of panel blocks or	≤ 1800 mm	2.03	1.60 / 2.20	1.10	3.57 / 4.91	2) + 85 **
- individual panels with panel blocks	≤ 2350 mm	2.53	1.60 / 2.20	1.10	4.49 / 6.17	2) + 100 **

Design

Panel design (examples)

8DJ20 switchgear:
Scheme 10-LST (2RK+1LST)

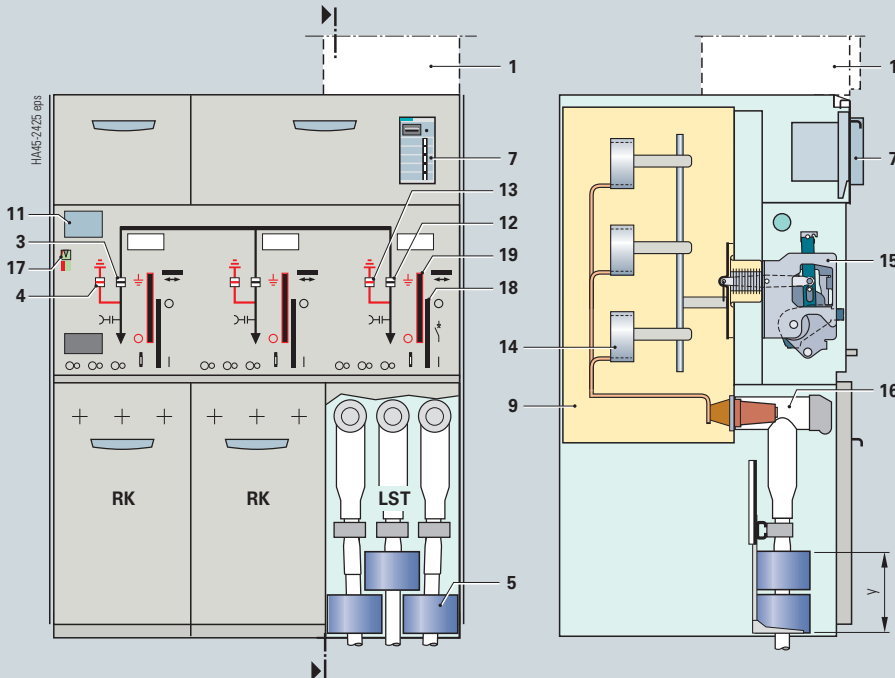

8DH10 switchgear:
Circuit-breaker feeder as panel type LST1

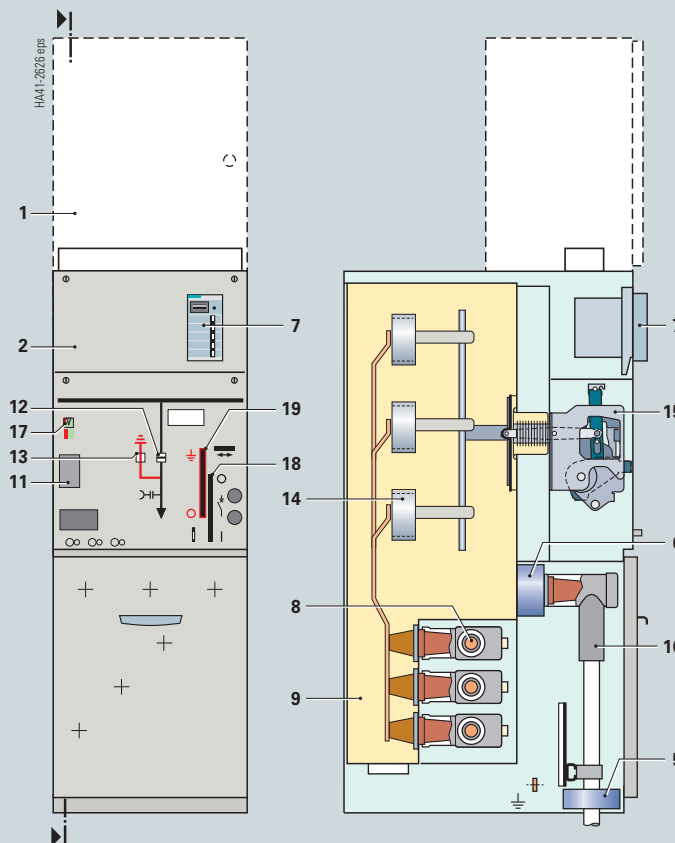

Legend:

- 1 Option: Low-voltage compartment
- 2 Niche for customer-side low-voltage equipment, removable cover
- 3 Switch position indicator for load-break function "CLOSED - OPEN"
- 4 Switch position indicator for earthing function "OPEN - EARTHED" in ring-main feeder
- 5 Option: Cable-type current transformer
- 6 Option: Three-phase current transformer (protection transformer)
- 7 Option: Protection device
- 8 Busbar system
- 9 Switchgear vessel, gas-filled
- 10 Option: Cable plug
- 11 Rating and type plate
- 12 Switch position indicator for disconnecting circuit-breaker "CLOSED - OPEN"
- 13 Switch position indicator for earthing function "OPEN - EARTHED" in circuit-breaker feeder
- 14 Disconnecting circuit-breaker: Circuit-breaker with disconnecting function and earthing function as three-position switch
- 15 Operating mechanism as "spring-operated CLOSED - spring-operated OPEN", "stored-energy OPEN" mechanism
- 16 Option: Cable T-plug
- 17 Ready-for-service indicator
- 18 Manual operation for disconnecting circuit-breaker operating mechanism
- 19 Manual operation for earthing switch operating mechanism

y = Mounting height of the current transformers, dependent on the core data

Components

Disconnecting circuit-breaker

Features

- Circuit-breaker as disconnecting circuit-breaker with disconnecting function, with the switch positions CLOSED-OPEN-EARTHED
- According to IEC 62 271-100 / VDE 0671-100
- Designed as three-position switch with the functions:
 - Circuit-breaker CLOSED-OPEN,
 - Disconnecting function (OPEN), and
 - Make-proof earthing switch
- System-conforming application for all 8DJ20 and 8DH10 switchgear in hermetically welded switchgear vessels, therefore climate-independent
- Operation via gas-tight, welded-in bushing at the front of the switchgear vessel

Switching functions and operating mechanisms

- Functional and quenching principle: "Rotating arc" or arc suppression coil system
- Quenching and insulating gas SF₆
- Operating mechanism designed as spring-operated CLOSED / spring-operated OPEN mechanism, stored-energy OPEN via protection system (relay, release, current transformer)
 - With manual operation (standard)
 - With motor operation (option) (24 V to 220 V DC, 110 V and 230 V AC) for the disconnecting circuit-breaker
- Operating mechanism designed as detachable lever mechanism

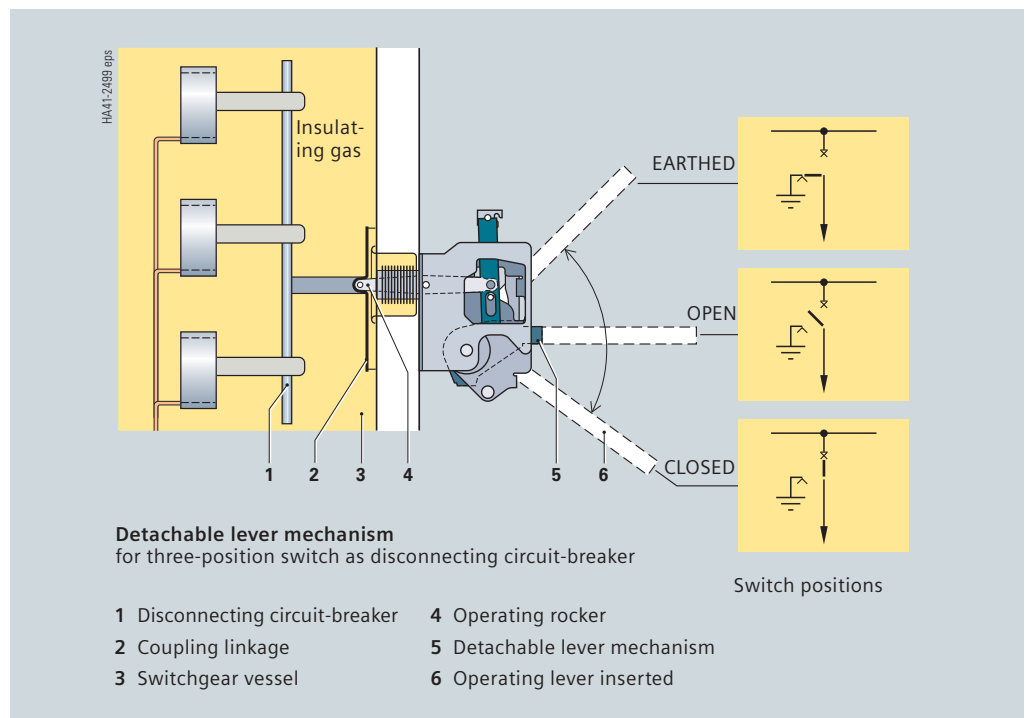

Equipment features and applications of the disconnecting circuit-breaker

Design	Standard	Option
Mechanism operation	Manual	Motor
Mechanism design	Spring-operated/stored-energy mechanism	Spring-operated/stored-energy mechanism
Mechanism functions	Spring-operated CLOSED, spring-operated OPEN	Spring-operated CLOSED, spring-operated OPEN
Mechanism actuation	With operating lever, detachable	With motor
Closing the disconnecting circuit-breaker	Mechanically "locally" with operating lever	Electrically with motor – "Remote" operation – "Local" operation (option)
Operating sequence (t = 3 min)	CO	CO (or O-t-CO)
Typical uses (examples)	Substation for wind parks, transformer switch, switchgear without auxiliary voltage supply	Substation for wind parks, transformer switch, customer transfer substation, line protection

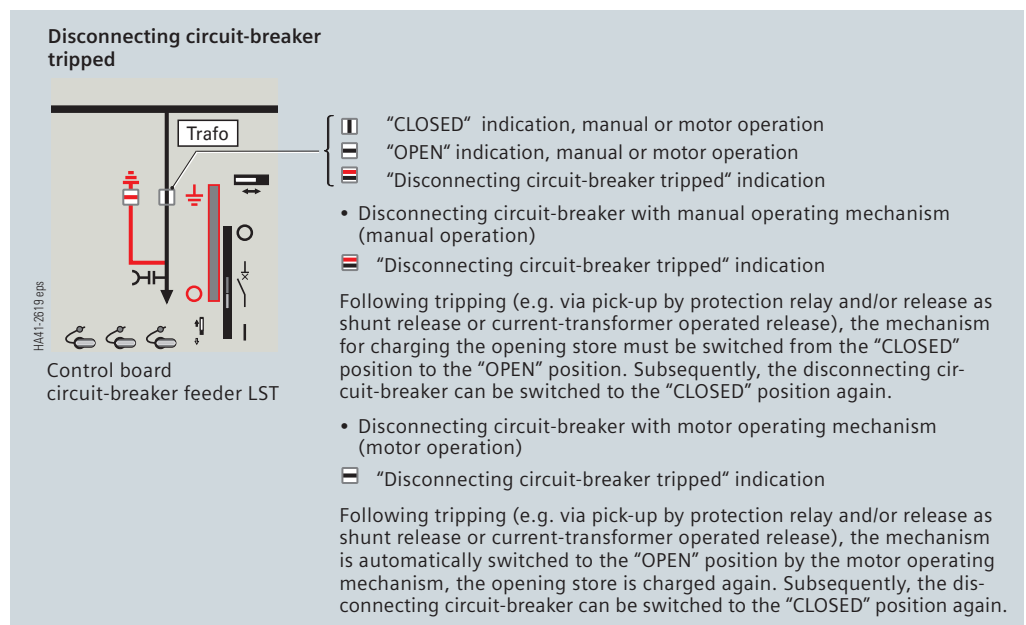

Components

Installation of current transformers type 4MC70 33 in 8DJ20 and 8DH10 switchgear

Features

- Designed as single-pole, ring-core current transformers
- Free of dielectrically stressed cast-resin parts (due to design)
- Insulation class E
- Inductive type
- Climate-independent

Installation

- 4MC70 33 cable-type current transformer for:
 - 8DJ20 switchgear feeder type LST
 - 8DH10 switchgear panel type LST1 as individual panel (500 mm wide) feeder type LST in panel blocks
- Arranged around the cable at the panel connection
- Transformers mounted on a supporting plate at the factory; final assembly around the cables on site

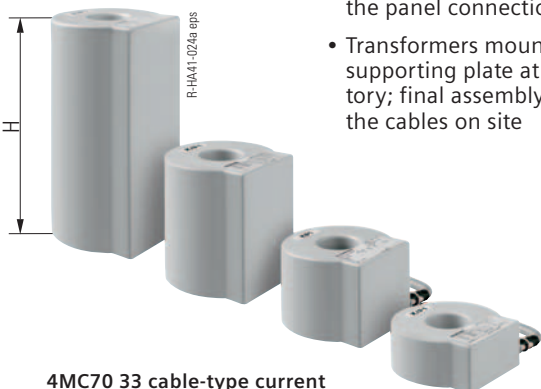

4MC70 33 cable-type current transformers, 4 different overall heights

Technical data

4MC70 33 cable-type current transformer

Primary data

Maximum equipment operating voltage U_m	0.72 kV
Rated current I_N	30 A to 600 A
Rated short-duration power-frequency withstand voltage (winding test)	3 kV
Rated thermal short-time withstand current I_{th}	25 kA
Rated continuous thermal current I_D	1.0 x I_N Option: 1.2 x I_N
Transient overload current	1.5 x I_D / 1 h or 2 x I_D / 0.5 h
Rated peak withstand current I_{dyn}	unlimited

Secondary data

Rated current	1 A (option: 5 A)	
On request: Measuring core	Class	0.2; 0.5; 1
	Overcurrent factor	FS10 (option: FS5)
	Rating	2.5 VA to 10 VA
Protection core (standard)	Class	10 P 10 P
	Overcurrent factor	10 20
	Rating	1.5 VA to 10 VA
Option on request: Secondary tap	1 : 2 (e.g. 150 A – 300 A)	

Dimensions

Overall height H , dependent on the core data	mm	50	100	170	285
Outside diameter		145 mm			
Inside diameter		55 mm			
For cable diameter		50 mm			

Other values on request

Installation of current transformers:
With 1200 mm switchgear height,
underneath 8DJ20 switchgear

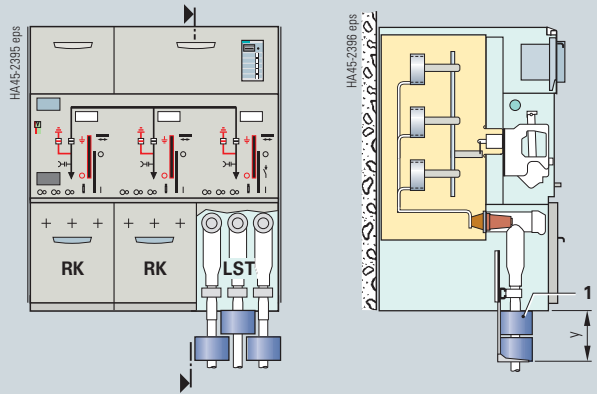

With 1400 mm switchgear height, inside or sometimes underneath 8DJ20 switchgear, dependent on the core data

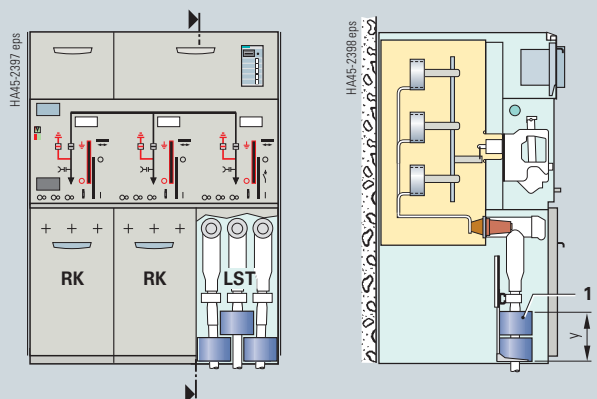

With 1760 mm switchgear height, inside or sometimes underneath 8DJ20 switchgear, dependent on the core data

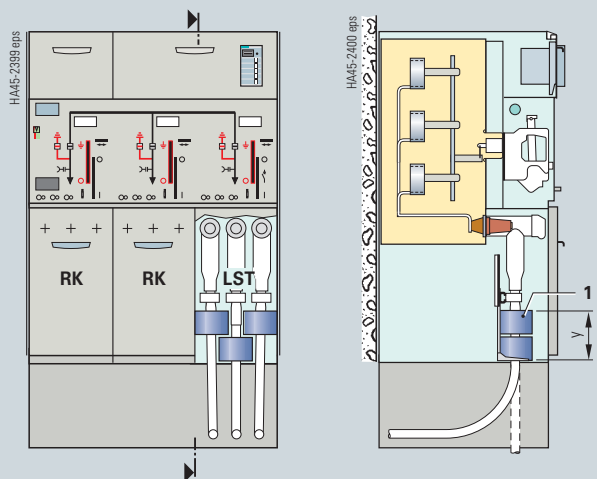

1 Cable-type current transformer type 4MC70 33

y = Mounting height of the current transformers, dependent on the core data

Installation of current transformers in 8DH10 switchgear

Features

- Designed as three-pole, ring-core current transformers
- Free of dielectrically stressed cast-resin parts (due to design)
- Insulation class E
- Inductive type
- Climate-independent

Installation

- For installation in individual panel type LST1
- Arranged outside the switchgear vessel on the bushings of the cable connection
- Mounted at the factory

Other designs (option)

Three-phase current transformer for protection equipment based on the c.t.-operated principle:

- Protection system 7SJ45 as definite-time overcurrent protection
- Definite-time overcurrent relay, make SEG, type WIC1-xP



4MC63
three-phase current transformer

Technical data

4MC63 11 three-phase current transformer
for $I_N \leq 400$ A and $I_D = 630$ A

Primary data

Maximum equipment operating voltage U_m	0.72 kV
Rated current I_N	A 400 300 200
Rated short-duration power-frequency withstand voltage (winding test)	3 kV
Rated thermal short-time withstand current I_{th}	25 kA
Rated continuous thermal current I_D	630 A
Transient overload current	$2 \times I_D / 0.5$ h
Rated peak withstand current I_{dyn}	unlimited

Secondary data

Rated current	A	1	0.75	0.5
Rating	VA	4	3	2
Rated current (option)		5 A		
Current at I_D		1.575 A		
Protection core	Class	10 P		
	Overcurrent factor	10		

Other values on request

Circuit-breaker panel type LST1 as individual panel

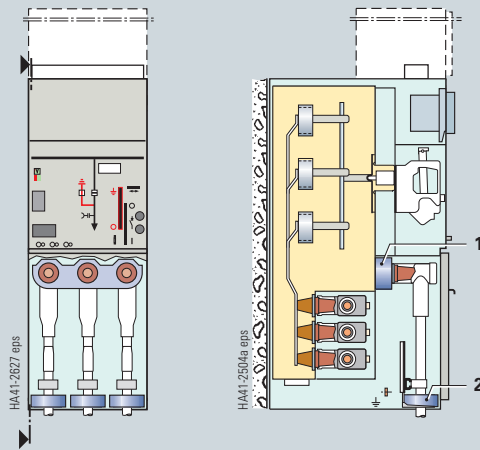

Circuit-breaker feeder type LST in panel block

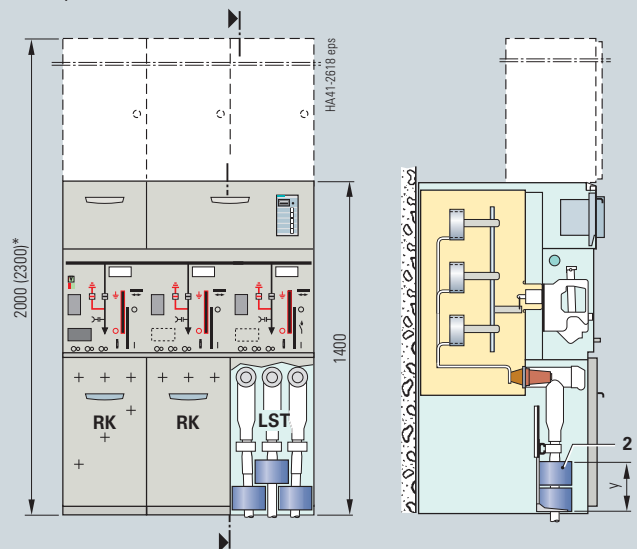

- 1 Three-phase current transformer type 4MC63 possible in LST1
- 2 Cable-type current transformer type 4MC70 33 possible in LST1, and LST in all panel blocks

For instructions concerning the use of double cables, see page 20.

Components

Cable connections

8DH10 switchgear

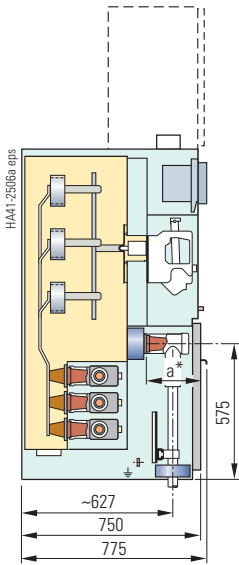

Panel type LST1

* Dimension a: Available mounting depth for plugs in mm

Cable connections for circuit-breaker feeders type LST in 8DH10 panels type LST1

Single cable connection (K) for 8DH10 panels type LST1

Single cable plugs				Necessary cable compartment cover			
Make	Single cable plug (K)	Design	Mounting depth of the plug mm	Standard (depth 36 mm)	deeper by (. . . mm)		
					+ 25 ¹⁾	+ 50 ¹⁾	+ 105 ²⁾
				Available mounting depth for plugs in mm			
				223	248	273	328
Euromold	430TB-630 (up to 24 kV)	s	183	•	–	–	–
	(K) 400TB/G	s	255	–	–	•	–
	(K) 400LB/G	s	202	•	–	–	–
	(K) 440TB/G	s	260	–	–	•	–
	AGT10/630, AGT20/630	s	185	•	–	–	–
	AGT L 10/630, AGT L 20/630	s	175	•	–	–	–
Südkabel	SEHDT (13/23)	s	280	–	–	–	•
	SET (12/24)	s	188	•	–	–	–
nkt cables	CB12-630, CB24-630	s	190	•	–	–	–
	AB24	i	190	•	–	–	–
Tyco Electronics Raychem	RSTI-L56xx	s	185	•	–	–	–
	On request: RICS 5139	i	222	o. r.	–	–	–
Kabeldon	90C 630-1/-2	i	172	•	–	–	–
Prysmian Kabel und Systeme (Pirelli Elektrik)	On request: FMCT s/j-400	s	265	–	–	o. r.	o. r.

s = Screened
i = Insulated

• Possible
– Not possible
o. r. = On request

Instructions for the use of double cables and 4MC70 33 cable-type current transformers:

- Depending on the make/type of the cable plug, a deep cable compartment cover is necessary
- Depending on the make/type of the cable plug, the 4MC70 33 cable-type current transformers are sometimes staggered, sometimes arranged underneath the switchgear
- Use of 4MC70 33 cable-type current transformers with double cables (K+K) in feeders
 - **8DH10, type LST1**
 - Possible with deep cable compartment cover, 300 mm deeper
 - Not possible with deep cable compartment cover, 25 mm, 50 mm or 105 mm deeper
 - **8DH10, type LST1 (in panel blocks)**
 - Possible with deep cable compartment cover, 105 mm deeper (on request) and 300 mm deeper
 - **8DJ20, type LST**
 - Possible with deep cable compartment cover, 105 mm deeper (on request) and 300 mm deeper

1) Cable compartment cover closed towards the bottom

2) Cable routing in extended baseframe

Double cable connection (K + K) for 8DH10 panels type LST1

Double cable plugs				Necessary cable compartment cover					
Make	Double cable plug (K+K) Type	Arrange-ment	Mounting depth of combination mm	Standard (depth 36 mm)	deeper by (. . . mm)				
					+25 ¹⁾	+50 ¹⁾	+105 ²⁾	+150 ²⁾	+300 ²⁾
				Available mounting depth for plugs in mm					
				223	248	273	328	368	518
Euromold	(K) 400TB/G + (K) 400LB/G with screw-type coupling insert (K) 400CP-LB	K + K	447	–	–	–	–	–	•
	430TB-630 + 300PB - 630 A (without coupling insert)	K + K	290	–	–	–	•	–	–
	(K) 400TB/G + (K) 400TB/G with screw-type coupling insert (K) 400CP	K + K	505	–	–	–	–	–	o. r.
	(K) 400TB/G + 430 TB (with (K) 400CP)	K + K	403	–	–	–	–	–	•
	AGT 20/630 + AGT 20/630 each with metal housing	K + K	370	–	–	–	–	–	•
	AGTL 20/630 + AGTL 20/630 each without metal housing	K + K	370	–	–	–	–	–	•
Südkabel	SEHDT (13/23) + SET (12/24)	K + K	450	–	–	–	–	–	•
	SET (12/24) + SET (12/24) with coupling insert KU23.2	K + K	378	–	–	–	–	–	•
	SET (12/24) + SEHDK (13/23)	K + K	298	–	–	–	•	–	–
nkt cables	CB 24-630 + CB 24-630 with coupling piece	K + K	370	–	–	–	–	–	•
	CB 24-630 + CC 24-630	K + K	290	–	–	–	•	–	–
	AB 24-630 + AB 24-630 with coupling piece CP 630 A	K + K	370	–	–	–	–	–	•
	AB 24-630 + AC 24-630	K + K	290	–	–	–	•	–	–
Tyco Electronics Raychem	RSTI 56xx + RSTI 56xx, with RSTI 56CP	K + K	365	–	–	–	–	–	•
	RSTI-L56xx + RSTI-CC-L56xx	K + K	290	–	–	–	•	–	–
Prysmian Kabel und Systeme (Pirelli Elektrik)	FMCT sj-400 + FMCT sj-400	K + K	490	–	–	–	–	–	o. r.
Combination of double cables and current transformers as three-phase current transformers		K + K	s. a.	–	–	–	•	–	•
as cable-type current transformers		K + K	s. a.	–	–	–	o. r.	–	•

Connection with cable plugs and surge arresters (K + Ü, or Ü + K) for 8DH10 panels type LST1

Cable plugs with surge arresters				Necessary cable compartment cover					
Make	Cable plugs (K) with surge arresters (Ü) Type	Arrange-ment	Mounting depth of combination mm	Standard (depth 36 mm)	deeper by (. . . mm)				
					+25 ¹⁾	+50 ¹⁾	+105 ²⁾	+150 ²⁾	+300 ²⁾
				Available mounting depth for combination in mm					
				223	248	273	328	368	518
Euromold	430TB-630 + 300SA-5, -10	(K+Ü)	290	–	–	–	•	–	–
	(K) 400TB/G + 400PB-..SA	(K+Ü)	410	–	–	–	–	–	•
	400PB-..SA + (K) 400LB/G	(Ü+K)	355	–	–	–	–	–	•
	400PB-..SA + AGT 20/630	(Ü+K)	330	–	–	–	–	–	•
	400PB-..SA + AGTL 20/630	(Ü+K)	330	–	–	–	–	–	•
Südkabel	SET (12/24) + SET (12/24) + MUT (13/23)	(K+K+Ü)	491	–	–	–	–	–	•
	SET (12/24) + MUT (13/23)	(K+Ü)	301	–	–	–	•	–	–
nkt cables	CB 12-630 + CSAxx, CB 24-630 + CSAxx	(K+Ü)	290	–	–	–	•	–	–
	AG 24-630 + ASA 24-5	(K+Ü)	285	–	–	–	•	–	–
Tyco Electronics Raychem	RSTI-L56xx + RSTI-CC-L56SAxx05 including coupling	(K+Ü)	290	–	–	–	•	–	–
	o.r.: RICS 5139 + RDA	(K+Ü)	275	o. r.	–	–	–	–	–

• Possible
– Not possible

o. r. = On request
s. a. = See above

Abbreviations:

K = Cable plug
Ü = Surge arrester

Floor openings: See Catalog HA 41.11 (8DH10)

Depending on additional options (e.g. surge arrester, 2nd cable, cable-type current transformer), other floor openings have to be provided as standard accordingly.

- 1) Cable compartment cover closed towards the bottom
- 2) Cable routing in extended baseframe

Components

Cable connections in 8DJ20 and 8DH10 switchgear, feeder type LST

Standard connection

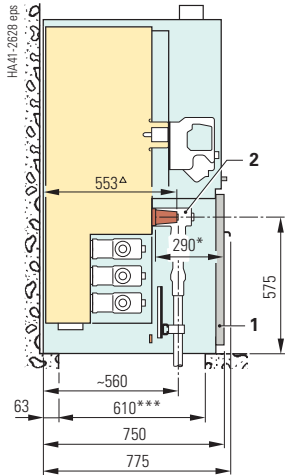

Standard cable compartment cover for feeder type LST for 8DJ20 and 8DH10 switchgear

Deep cable compartment cover for 8DH10 switchgear with pressure absorber system (overall height of switchgear 1700 mm):

Possible connection combinations for circuit-breaker feeder LST or LST1

Arrangement of connection combinations	Required cable compartment cover, deeper by ...mm			
	+25	+105	+150	+300
for LST (width = 350 mm)				
K + K	-	•	-	•
K + Ü	•	•	•	-
K + K + Ü	-	-	-	•
for LST1 (width = 500 mm)				
K + K	-	•	-	•
K + Ü	-	•	-	-
K + K + Ü	-	-	-	•

• Possible – Not possible

Abbreviations:

K = Cable plug
Ü = Surge arrester

- 1) In the case of 1200 mm overall height of 8DJ20 switchgear the cable T-plugs of the double cable or the surge arresters protrude into the cable basement
- 2) No double cable connection or cable connection with surge arresters for cable compartment covers deeper by +50 mm are available on the market at present
- 3) Not possible, because the surge arrester would reach below the closed cable compartment cover

Double cable connection (examples)

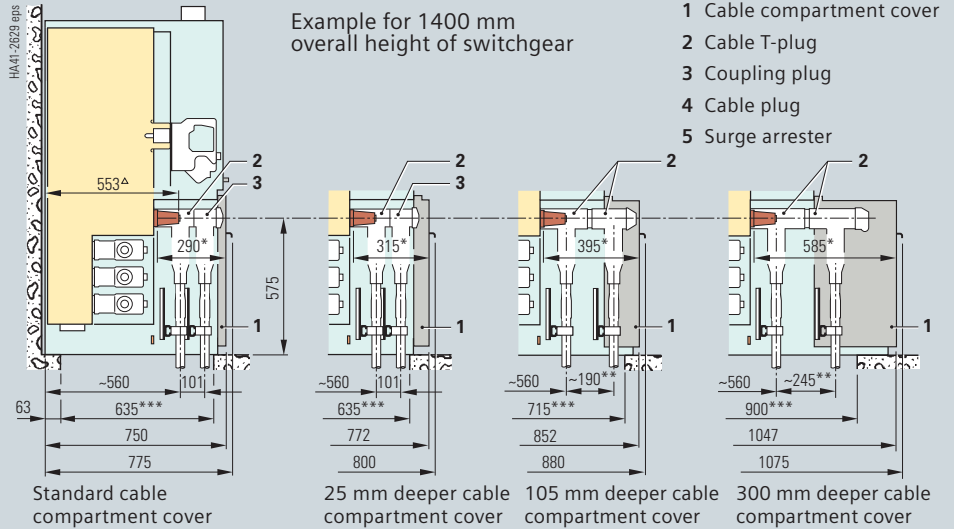

Switchgear Type	Overall height of switchgear mm	Required cable compartment cover deeper by ...					
		Standard	+25 mm	+50 mm	+105 mm	+150 mm	+300 mm
8DJ20	1200 ¹⁾	•	•	- ²⁾	•	o. r.	•
8DJ20 / 8DH10	1400	•	•	- ²⁾	•	o. r.	•
8DJ20	1760	•	•	- ²⁾	•	o. r.	•

Connection with cable plug and surge arrester (examples)

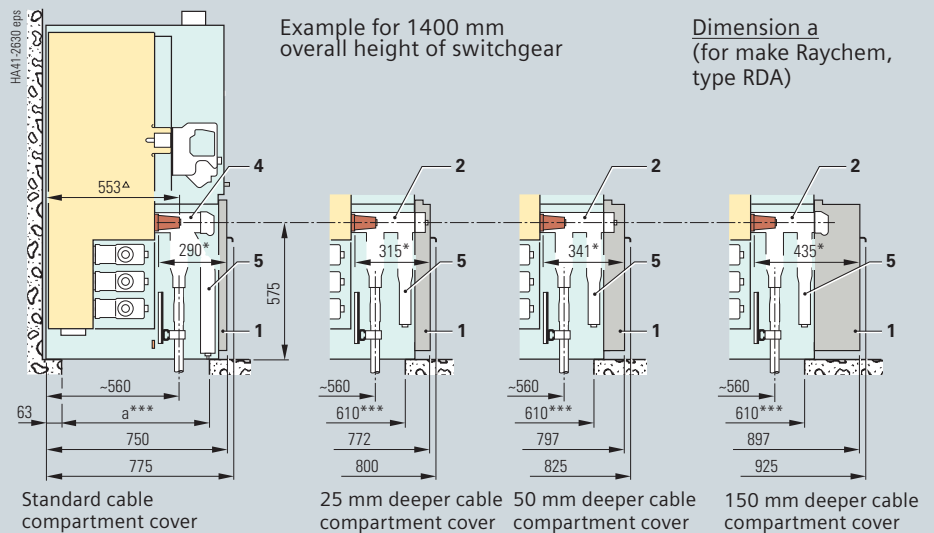

Switchgear Type	Overall height of switchgear mm	Required cable compartment cover deeper by ...					
		Standard	+25 mm	+50 mm	+105 mm	+150 mm	+300 mm
8DJ20	1200	- ³⁾	- ³⁾	- ²⁾	•	- ³⁾	•
8DJ20 / 8DH10	1400	•	•	- ²⁾	•	•	•
8DJ20	1760	•	•	- ²⁾	•	•	•

Δ Dimension for bushing as interface type "C" with bolted contact (M16)

* Max. mounting space for cable and/or surge arrester

** Dependent on the type of cable plug

*** Depth of floor opening

• Possible
- Not possible
o. r. = On request

Components

Cable connections in 8DJ20 and 8DH10 switchgear, feeder type LST

Double cable connection (depending on the overall height of the switchgear; refer to page 22)

Double cable plugs			Connection combination			Required cable compartment cover					
Make	Serial No.	Cable plugs Type	Design	Arrangement	Mounting depth of combination mm	Available depth (. . . mm)					
						Standard (depth 36 mm)	deeper by (. . . mm)				
						290	315	341	395	435	585
Euromold	1	(K) 400 TB/G + (K) 400 TB/G with screw-type coupling insert (K) 400 CP	screened	K + K	505	–	–	–	–	–	•
	2	(K) 400 TB/G + (K) 400 LB/G (with (K) 400 CP-LB)	screened	K + K	447	–	–	–	–	–	•
	3	430 TB + 300 PB - 630 A (without coupling insert)	screened	K + K	290	•	–	–	–	–	–
	4	(K) 400 TB/G + 430 TB (with (K) 400 CP)	screened	K + K	403	–	–	–	–	–	•
	5	AGT 20/630 + AGT 20/630 ⁴⁾	screened	K + K	370	–	–	–	•	–	–
	6	AGTL 20/630 + AGTL 20/630 each without metal housing	screened	K + K	370	–	–	–	•	–	–
Südkabel	7	SEHDT (13/23) + SEHDT (13/23) + KU 23	screened	K + K	540	–	–	–	–	–	•
	8	SEHDT (13/23) + SET (12/24) + KU 23	screened	K + K	450	–	–	–	–	–	•
	9	SET (12/24) + SET (12/24) with coupling piece KU 23.2	screened	K + K	378	–	–	–	•	–	–
nkt cables	10	CB 24-630 + CB 24-630 with coupling piece CP 630C	screened	K + K	370	–	–	–	o. r.	–	•
	11	CB 24-630 + CC 24-630	screened	K + K	290	•	–	–	–	–	–
	12	AB 24-630 + AB 24-630 with coupling piece CP 630A	insulated	K + K	370	–	–	–	o. r.	–	•
	13	AB 24-630 + AC 24-630	insulated	K + K	290	–	o. r.	–	–	–	–
Tyco Electronics Raychem	14	RSTI 56xx + RSTI 56CP	screened	K + K	365	–	–	–	–	o. r.	•
	15	RSTI-L56xx + RSTI-CC-L56xx	screened	K + K	290	•	–	–	–	–	–
Combination of double cables and current transformers as three-phase current transformers				K + K	s. a.	–	–	–	–	–	–
as cable-type current transformers				K + K	s. a.	–	–	–	o. r.	o. r.	•

Connection with cable plugs and surge arresters (depending on the overall height of the switchgear; refer to page 22)

Cable plugs with surge arresters			Connection combination			Required cable compartment cover					
Make	Serial No.	Cable plugs with surge arresters or Surge arresters with cable plugs Type	Design	Arrangement	Mounting depth of combination mm	Available depth (. . . mm)					
						Standard (depth 36 mm)	deeper by (. . . mm)				
						290	315	341	395	435	585
Euromold	1	(K) 400 TB/G + 400 PB - . . SA	screened	K + Ü	410	–	–	–	–	•	–
	2	430 TB + 300 SA-5, -10	screened	K + Ü	290	•	–	–	–	–	–
	3	400 PB - . . SA + (K) 400 LB/G	screened	Ü + K	355	–	–	–	•	–	–
	4	400 PB - . . SA + AGT 20/630 (screened ⁴⁾)	screened	Ü + K	330	–	–	–	•	–	–
	5	400 PB - . . SA + AGTL 20/630 (screened)	screened	Ü + K	330	–	–	–	•	–	–
Südkabel	6	SET (12/24) + SET (12/24) + MUT (13/23) with coupling piece KU 23.2	screened	K + K + Ü	491	–	–	–	–	–	•
	7	SET (12/24) + MUT (13/23)	screened	K + Ü	301	–	•	–	–	–	–
	8	SEHDT (13/23) ⁴⁾ + MUW (12/22) ⁴⁾	screened	K + Ü	435	–	–	–	–	•	–
	9	SEHDT (13/23) ⁴⁾ + MUT 33 ⁴⁾	screened	K + Ü	516	–	–	–	–	–	•
nkt cables	10	CB 24-630 + CSA 24-5	screened	K + Ü	290	•	–	–	–	–	–
	11	AB 24-630 + ASA 24-5	insulated	K + Ü	285	–	•	–	–	–	–
Tyco Electronics Raychem	12	RICS 5139 + RDA . . .	insulated	K + Ü	275	•	–	–	–	–	–
	13	RSTI-L56xx + RSTI-L56 SA - xx - 05 + coupling piece (= RSTI 56 - CC - L56 SAxx 05)	screened	K + Ü	290	•	–	–	–	–	–
	14	RICS 5139 + RDA	insulated	K + Ü	275	•	–	–	–	–	–

• Possible

– Not possible

o. r. = On request

s. a. = See above

Abbreviations:

K = Cable plug

Ü = Surge arrester

Floor openings: See Catalogs HA 41.11 (8DH10) and HA 45.31 (8DJ20)

Depending on additional options (e.g. surge arrester, 2nd cable, cable-type current transformer), other floor openings have to be provided as standard accordingly.

1) Cable compartment cover closed towards the bottom

2) Cable routing in extended base frame for arrangement of K + K

3) Cable routing in extended base frame for arrangement of Ü + K

4) With metal housing

Components

Protection system

Protection devices available as standard protection systems consisting of:

- Protection devices
- Releases at the disconnecting circuit-breaker designed as
 - Shunt release (f)
 - or
 - C.t.-operated release (low-energy 0.1 Ws)
- Current transformers designed as
 - Cable-type current transformer (standard)
 - Three-phase current transformer optionally for 8DH10 panels type LST1

Mounting location

- Standard for 8DJ20 and 8DH10:
 - In the low-voltage niche of the feeder panel
- Option:
 - In the low-voltage compartment of the circuit-breaker feeder
 - Type LST (8DJ20 and 8DH10)
 - Type LST1 (only for 8DH10)

Protection devices

- Protection devices based on “c.t.-operated principle”
 - Make Siemens, type 7SJ45
 - Make SEG, types WIC 1-2P, WIC 1-3P, WIP-1
- Protection devices with auxiliary voltage supply
 - Make Siemens, type 7SJ46
 - Other types on request

Examples for transformer protection

Operating voltage kV	Transformer rating kVA	Available relay types
6	> 160	WIC 1-2P, 7SJ45, 7SJ46
10	> 200	7SJ45, 7SJ46
	> 250	WIC 1-2P
13.8	> 250	7SJ45, 7SJ46
	> 400	WIC 1-2P
15	> 315	7SJ45, 7SJ46
	> 400	WIC 1-2P
20	> 400	7SJ45, 7SJ46
	> 500	WIC 1-2P

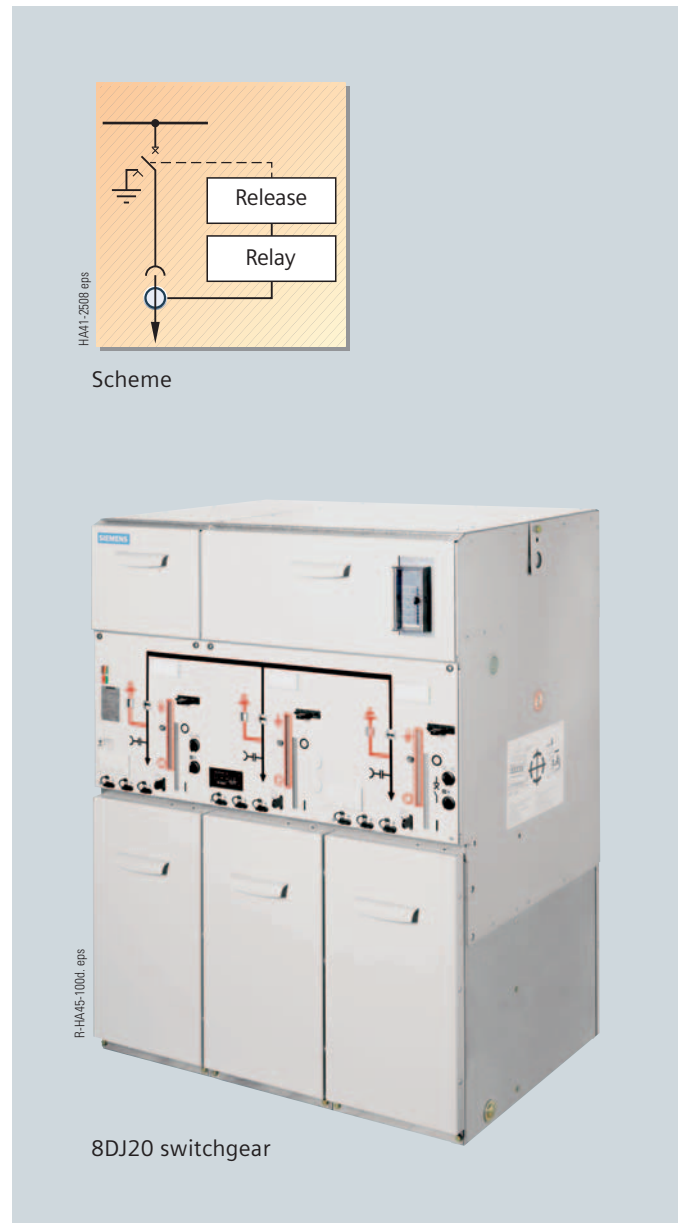

Shipping

Transport data for 8DJ20 switchgear

Scheme no.	Version (abbreviations)	Switchgear height (without ¹⁾ LV compartment) mm	Transport dimensions ¹⁾			Volume m ³	Gross weight ²⁾ approx. kg
			Width m	Height m	Depth m		

Scheme no.	Version (abbreviations)	Switchgear height (without ¹⁾ LV compartment) mm	Transport dimensions ¹⁾			Volume m ³	Gross weight ²⁾ approx. kg
			Width m	Height m	Depth m		

Transport in Europe by rail, truck, container

Packing with PE protective foil and wooden base

Scheme no.	Version (abbreviations)	Switchgear height (without ¹⁾ LV compartment) mm	Width m	Height m	Depth m	Volume m ³	Gross weight approx. kg
10	2RK+1LST	1200	1.45	1.4	1.10	2.23	450
		1400	1.45	1.6	1.10	2.55	480
		1760	1.45	1.96	1.10	3.13	510
20	1RK+1LST	1200	1.10	1.4	1.10	1.69	350
		1400	1.10	1.6	1.10	1.94	370
		1760	1.10	1.96	1.10	2.37	400
21	1K(E)+1LST	1200	1.10	1.4	1.10	1.69	350
		1400	1.10	1.6	1.10	1.94	370
		1760	1.10	1.96	1.10	2.37	400
71	3RK+1LST	1200	1.80	1.4	1.10	2.77	540
		1400	1.80	1.6	1.10	3.17	580
		1760	1.80	1.96	1.10	3.88	620

Transport overseas by seafreight

Packing with PE protective foil and seaworthy crate

Scheme no.	Version (abbreviations)	Switchgear height (without ¹⁾ LV compartment) mm	Width m	Height m	Depth m	Volume m ³	Gross weight approx. kg
10	2RK+1LST	1200	1.45	2.0	1.15	3.34	480
		1400	1.45	2.0	1.15	3.34	500
		1760	1.45	2.0	1.15	3.34	540
20	1RK+1LST	1200	1.10	2.0	1.15	2.53	410
		1400	1.10	2.0	1.15	2.53	430
		1760	1.10	2.0	1.15	2.53	470
21	1K(E)+1LST	1200	1.10	2.0	1.15	2.53	410
		1400	1.10	2.0	1.15	2.53	430
		1760	1.10	2.0	1.15	2.53	470
71	3RK+1LST	1200	1.80	2.0	1.15	4.14	550
		1400	1.80	2.0	1.15	4.14	570
		1760	1.80	2.0	1.15	4.14	620

1) Switchgear with low-voltage compartment:
Please observe other transport dimensions and weights.

2) Depending on the relevant equipment,
e.g. motor operating mechanism.

Abbreviations:

RK = Ring-main feeder

K(E) = Cable feeder for radial cable connection
with make-proof earthing switch

LST = Circuit-breaker feeder with disconnecting function

Standards

Standards, specifications, guidelines

Standards

The 8DJ/8DH switchgear types comply with the relevant standards and specifications applicable at the time of type tests.

In accordance with the harmonization agreement reached by the countries of the European Community, their national specifications conform to the IEC standard.

Overview of standards (July 2008)

		IEC standard	VDE standard	EN standard
Switchgear	8DJ, 8DH	IEC 62 271-1	VDE 0671-1	EN 62 271-1
		IEC 62 271-200	VDE 0671-200	EN 62 271-200
Switching devices	Circuit-breaker	IEC 62 271-100	VDE 0671-100	EN 62 271-100
	Disconnecter and earthing switch	IEC 62 271-102	VDE 0671-102	EN 62 271-102
	Switch-disconnector	IEC 60 265-1	VDE 0670-301	EN 60 265-1
	Switch-disconnector / fuse combination	IEC 62 271-105	VDE 0671-105	EN 62 271-105
	HV HRC fuses	IEC 60 282-1	VDE 0670-4	EN 60 282
	Voltage detecting systems	IEC 61 243-5	VDE 0682-415	EN 61 243-5
Degree of protection	–	IEC 60 529	VDE 0470-1	EN 60 529
Insulation	–	IEC 60 071	VDE 0111	EN 60 071
Instrument transformers	Current transformers	IEC 60 044-1	VDE 0414-1	EN 60 044-1
	Voltage transformers	IEC 60 044-2	VDE 0414-2	EN 60 044-2
	Combined transformers	IEC 60 044-3	VDE 0414-5	EN 60 044-3
Installation	–	IEC 61 936-1	VDE 0101	–

Type of service location

8DJ/8DH switchgear can be used as indoor installations in accordance with IEC 61 936 (Power installations exceeding 1 kV AC) and VDE 0101:

- Outside lockable electrical service locations at places which are not accessible to the public. Enclosures of switchgear can only be removed with tools.
- Inside lockable electrical service locations. A lockable electrical service location is a place outdoors or indoors that is reserved exclusively for housing electrical equipment and which is kept under lock and key. Access is restricted to authorized personnel and persons who have been properly instructed in electrical engineering. Untrained or unskilled persons may only enter under the supervision of authorized personnel or properly instructed persons.

Climate and ambient conditions

8DJ/8DH switchgear types are fully enclosed and insensitive to climatic conditions.

- Climatic tests fulfilled in accordance with IEC 60 932 (report)
- All medium-voltage devices (except for HV HRC fuses) are installed in a gas-tight, welded stainless steel switchgear vessel which is filled with SF₆ gas
- Live parts outside the switchgear vessel are provided with single-pole enclosure
- At no point can creepage currents flow from high-voltage potentials to earth
- Operating mechanism parts which are functionally important are made of corrosion-proof materials
- Bearings in operating mechanisms are designed as dry-type bearings and do not require lubrication.

Terms

- “Make-proof earthing switches” are earthing switches with short-circuit making capacity according to
 - IEC 62 271-102 and
 - VDE 0671-102
 - Circuit-breaker as disconnecting circuit-breaker (LST) with disconnecting function as three-position switch with the functions:
 - Circuit-breaker (CLOSED-OPEN)
 - Disconnecting function (OPEN) and
 - Make-proof earthing switch
- LST = Circuit-breaker with disconnecting function

Responsible for

Technical contents:

Christoph Maul
Siemens AG, Dept. E D MV 2 PPM
Erlangen

General editing:

Claudia Kühn-Sutiono,
Gabriele Pollok
Siemens AG, Dept. E CC MCC R
Erlangen

Published by and copyright © 2008:

Siemens AG
Energy Sector
Freyeslebenstrasse 1
91058 Erlangen, Germany

Siemens AG
Energy Sector
Power Distribution Division
Medium Voltage
Postfach 32 40
91050 Erlangen, Germany
www.siemens.com/medium-voltage-switchgear

For more information, please contact our
Customer Support Center.

Phone: +49 180 524 70 00

Fax: +49 180 524 24 71

(Charges depending on provider)

E-mail: support.energy@siemens.com

Order No. E50001-K1445-E311-A2-7600

Printed in Germany

Dispo 31601

KG 08.08 4.0 28 En

6101/13189 103315

Printed on elementary chlorine-free bleached paper.

All rights reserved.

If not stated otherwise on the individual pages of this
catalog, we reserve the right to include modifications,
especially regarding the stated values, dimensions and weights.

Drawings are not binding.

All product designations used are trademarks or product
names of Siemens AG or other suppliers.

If not stated otherwise, all dimensions in this
catalog are given in mm.

Subject to change without prior notice.

The information in this document contains general
descriptions of the technical options available, which
may not apply in all cases. The required technical
options should therefore be specified in the contract.