



Switchgear Type 8DJH for Secondary Distribution Systems up to 24 kV, Gas-Insulated

Medium-Voltage Switchgear

Catalog HA 40.2 · 2009

Answers for energy.

SIEMENS

R-HA40-109.eps



R-HA40-112.eps



R-HA40-110.eps

R-HA40-111.eps



Switchgear Type 8DJH for Secondary Distribution Systems up to 24 kV, Gas-Insulated

Medium-Voltage Switchgear

Catalog HA 40.2 · 2009

Contents	Pages
Application, requirements	
Features, classification	4 and 5
Technical data	
Electrical data, filling pressure, temperature	6
Switching capacity, classification	7 and 8
Switchgear installation, room planning	9 and 10
Product range	
Preferred scheme versions	11 and 12
Individual panels, individual modules	13 to 15
Air-insulated billing metering panels	16
Design	
Panel design	17 to 19
Operation	20
Components	
Three-position switch-disconnector	21 to 23
Vacuum circuit-breaker	24 to 27
Busbar extension	28
HV HRC fuse assembly	29 to 33
Instrument transformers	34 to 38
Panel connections, cable connections, cable sealing ends	39 to 45
Interlocks, locking devices	46
Indicating and measuring equipment	47 to 50
Transformer monitoring, protection systems	51 and 52
Low-voltage equipment	53 and 54
Dimensions	
Individual panels, standard switchgear, metering panel combinations	55 to 66
Floor openings and fixing points	67 to 70
Installation	
Shipping data, transport	71 and 72
Standards	
Standards, specifications, guidelines	73 to 75



The products and systems described in this catalog are manufactured and sold according to a certified quality and environmental management system (acc. to ISO 9001 and ISO 14001). (DQS Certificate Reg. No. DQS 003473 QM UM). The certificate is accepted in all IQNet countries.

Application, Requirements

Features

8DJH switchgear is a factory-assembled, type-tested, 3-pole metal-enclosed, single-busbar switchgear for indoor installation:

- Up to 24 kV
- Feeder currents up to 630 A
- Busbar current 630 A.

Typical uses

8DJH switchgear is used – even under severe ambient conditions – for power distribution in secondary distribution systems, such as

- Substations, customer transfer substations, distribution substations and switching substations of power supply and public utilities
- Industrial plants, such as:
 - Wind power stations, high-rise buildings, airports
 - Lignite open-cast mines, underground railway stations
 - Sewage treatment plants, port facilities
 - Traction power supply systems
 - Automobile industry, petroleum industry
 - Chemical industry, cement industry.

Modular design

- Individual panels and panel blocks can be lined up and extended at will – without gas work on site
- Low-voltage compartment available in 3 overall heights, wiring to the panel via plug connectors.

Reliability

- Type and routine-tested
- Standardized, NC production processes
- More than 500,000 switchgear panel types 8DJ/8DH in operation in hermetically welded design.

Quality and environment

- Quality and environmental management system according to DIN EN ISO 9001 and DIN EN ISO 14001.

Personal safety

- Safe-to-touch and hermetically sealed primary enclosure
- HV HRC fuses and cable sealing ends are only accessible when outgoing feeders are earthed
- Operation only possible when enclosure is closed
- Logical mechanical interlocking
- Capacitive voltage detecting system to verify safe isolation from supply
- Feeder earthing via make-proof earthing switches.

Security of operation

- Hermetically sealed primary enclosure
 - Independent of environmental effects such as pollution, humidity and small animals
- Sealed for life:
 - Welded switchgear vessel
 - Welded-in bushings
- Operating mechanism parts maintenance-free (IEC/EN 62271-1/VDE 0671-1)
- Operating mechanisms of switching devices accessible outside the switchgear vessel
- Switchgear interlocking system with logical mechanical interlocks
- Mechanical position indicators integrated in the mimic diagram.

Cost-efficiency

Extremely low “life-cycle costs” throughout the entire product service life thanks to:

- Maintenance-free design
- Climatic independence
- Minimum space requirements
- Maximum availability.

Security of investment

Innovative developments, e.g.:

- Modular design
- Switchgear extension without gas work on site
- Maintenance-free vacuum circuit-breaker
- SIPROTEC protection device family as well as external makes.

Technology

- Maintenance-free components
- Complete switchgear climate-independent
- Three-pole primary enclosure, metal-enclosed
- Insulating gas SF₆
- Welded switchgear vessel without seals, made of stainless steel, with welded-in bushings for electrical connections and mechanical components
- Three-position switch-disconnector with load-break function and make-proof earthing function
- Vacuum circuit-breaker
- Cable connection for bushings with outside cone
- Connection with cable plugs
 - In ring-main feeders and circuit-breaker feeders with bolted contact (M16)
 - In transformer feeders with plug-in contact or optionally with bolted contact (M16)
- Pressure relief downwards, optionally to the rear or upwards via pressure absorber systems
- Wall-standing arrangement, optionally free-standing arrangement.

Standards

See page 73.

Requirements

Classification

8DJH switchgear is classified according to IEC/EN 62271-200/
VDE 0671-200.

Design and construction

Partition class	PM (partition of metal)
Loss of service continuity category for panels or panel blocks <ul style="list-style-type: none"> – With HV HRC fuses (T, H) – Without HV HRC fuses (R, L, ...) 	LSC 2A LSC 2B
Accessibility to compartments (enclosure) <ul style="list-style-type: none"> – Busbar compartment – Switching-device compartment – Low-voltage compartment (option) – Cable compartment for panels or panel blocks <ul style="list-style-type: none"> – With HV HRC fuses (T) – Without HV HRC fuses (R, L, ...) – Only cable feeder (K) – Metering panels (air-insulated) (M) 	<ul style="list-style-type: none"> – Non-accessible – Non-accessible – Tool-based – Interlock-controlled – Interlock-controlled – Tool-based – Tool-based

Internal arc classification (option)

Designation of the internal arc classification IAC	Rated voltage 7.2 kV to 24 kV
IAC class for <ul style="list-style-type: none"> – Wall-standing arrangement – Free-standing arrangement 	IAC A FL IAC A FLR
Type of accessibility A <ul style="list-style-type: none"> – F – L – R 	Switchgear in closed electrical service location, access “for authorized personnel only” (according to IEC/EN 62271-200) Front Lateral Rear (for free-standing arrangement)
Arc test current	Up to 21 kA
Test duration	1 s

Technical Data

Electrical data of the switchgear

Rated insulation level	Rated voltage U_r	kV	7.2	12	15	17.5	24	
	Rated short-duration power-frequency withstand voltage U_d – Phase-to-phase, phase-to-earth, open contact gap – Across the isolating distance	kV	20	28 / 42 *)	36	38	50	
		kV	23	32 / 48 *)	39	45	60	
	Rated lightning impulse withstand voltage U_p – Phase-to-phase, phase-to-earth, open contact gap – Across the isolating distance	kV	60	75	95	95	125	
kV		70	85	110	110	145		
Rated frequency f_r		Hz	50 / 60				→	
Rated normal current I_r *)	for ring-main feeders	A	400 or 630				→	
	for busbar	A	630				→	
	for circuit-breaker feeders	A	250 or 630				→	
	for transformer feeders	A	200 1)				→	
Rated short-time withstand current I_k	for switchgear with $t_k = 1$ s	to kA	25	25	25	25	20	
	for switchgear with $t_k = 3$ s (design option)	kA	20				→	
Rated peak withstand current I_p		to kA	63	63	63	63	50	
Rated short-circuit making current I_{ma}	for ring-main feeders	to kA	63 2)	63 2)	63 2)	63 2)	50	
	for circuit-breaker feeders	to kA	63				→	
	for transformer feeders	kA	25				→	
Filling pressure (pressure values at 20 °C)	Rated filling level p_{re} for insulation (absolute)	kPa	150				→	
	Minimum functional level p_{re} for insulation (absolute)	kPa	130				→	
Ambient air temperature T	without secondary equipment	°C	–25 / –40 *) to +70					→
	with secondary equipment	°C	–5 / –15 3) / –25 3) to +55					→
	Storage/transport including secondary systems	°C	–40 to +70					→
Degree of protection	for parts of the primary circuit under high voltage		IP 65					→
	for switchgear enclosure		IP2X / IP3X *)					→
	for low-voltage compartment		IP3X / IP4X *)					→

*) Design option

1) Depending on HV HRC fuse-link

2) 52.5 kA at 60 Hz

3) Depending on the secondary equipment used

Technical Data

Switching capacity and classification of switching devices

Three-position switch-disconnector

Switching capacity for general-purpose switches (class E3) according to IEC/EN 60265-1/VDE 0670-301

Rated voltage U_r		kV	7.2	12	15	17.5	24
Test duty 1	Rated mainly active load breaking current	100 operations I_1	A 630				
		20 operations $0.05 I_1$	A 31.5				
Test duty 2a	Rated closed-loop breaking current I_{2a}	A	630				
Test duty 3	Rated no-load transformer breaking current I_3	A	40				
Test duty 4a	Rated cable-charging breaking current I_{4a} (I_c or I_6)	A	68				
Test duty 4b	Rated line-charging breaking current I_{4b}	A	68				
Test duty 5	Rated short-circuit making current I_{ma}	up to kA	63 ¹⁾	63 ¹⁾	63 ¹⁾	63 ¹⁾	50
Test duty 6a	Rated earth-fault breaking current I_{6a} (I_e)	A	200				
Test duty 6b	Rated cable-charging breaking current and line-charging breaking current under earth-fault conditions I_{6b} ($\sqrt{3} \cdot I_{CL}$)	A	115				
–	Cable-charging breaking current under earth-fault conditions with superimposed load current $I_L + \sqrt{3} \cdot I_{CL}$	A	630 + 50				
Number of operating cycles, mechanical / Classification		n	1000 / M1				
Number of operating cycles, electrical / Classification		n	100 / E3				

Switching capacity for make-proof earthing switch

Rated short-circuit making current I_{ma}	up to kA	63 ¹⁾	63 ¹⁾	63 ¹⁾	63 ¹⁾	50
Number of operating cycles, mechanical / Classification		n	1000 / M0			
Number of short-circuit making operations / Classification		n	5 / E2			

Switch-disconnector/fuse combination

Switching capacity for switch-disconnector/fuse combination (according to IEC/EN 62271-105/VDE 0671-105)

Rated normal current	A	200 ²⁾				
Rated transfer current I_4	A	1500	1500	1300	1300	1300
Maximum transformer rating	kVA	1000	1250	1600	1600	1600 ³⁾

Switching capacity for make-proof earthing switch, with HV HRC fuse on feeder side

Rated short-circuit making current I_{ma}	kA	5				
Rated short-time withstand current I_k with $t_k = 1$ s	kA	2				

1) 52.5 kA at 60 Hz

2) Depending on HV HRC fuse-link

3) 2000 kVA on request

Technical Data

Switching capacity and classification of switching devices

Vacuum circuit-breaker

Switching capacity according to IEC/EN 62271-100 / VDE 0671-100

Type 1.1 for individual switchgear panels and panel blocks

		7.2	12	15	17.5	24
Rated voltage U_r	kV	7.2	12	15	17.5	24
Rated normal current of feeders I_r	A	630				→
Rated short-time withstand current I_k for switchgear with $t_k = 1$ s	$I_k (I_{th})$ kA	25	25	20	20	20
Rated short-time withstand current I_k for switchgear with $t_k = 3$ s	$I_k (I_{th})$ kA	20				→
Rated peak withstand current I_p	up to kA	63	63	50	50	50
Rated short-circuit breaking current I_{sc}	up to kA	25	25	20 ¹⁾	20 ¹⁾	20
Rated short-circuit making current I_{ma}	up to kA	63	63	50	50	50
Number of mechanical operating cycles for disconnect/earthing switch / Classification	n	1000 / M0				→
Number of mechanical operating cycles for circuit-breaker / Classification	n	10,000 / M2				→
Classification, electrical		E2, C2				→
Rated operating sequence		O - 0.3 s - CO - 3 min - CO				→
Number of short-circuit breaking operations	n	25 or 50				→

Type 2 for individual switchgear panels and panel blocks

		7.2	12	15	17.5	24
Rated voltage U_r	kV	7.2	12	15	17.5	24
Rated normal current of feeders I_r	A	250, 630				→
Rated short-time withstand current I_k for switchgear with $t_k = 1$ s	$I_k (I_{th})$ kA	20	20	20	20	16
Rated short-time withstand current I_k for switchgear with $t_k = 3$ s (design option)	$I_k (I_{th})$ kA	20	20	20	20	16
Rated peak withstand current I_p	up to kA	50	50	50	50	40
Rated short-circuit breaking current I_{sc}	up to kA	20 [*])	20 [*])	20 [*])	20 [*])	16 ²⁾
Rated short-circuit making current I_{ma}	up to kA	50	50	40	40	40
Number of mechanical operating cycles for disconnect/earthing switch / Classification	n	1000 / M0				→
Number of mechanical operating cycles for circuit-breaker / Classification	n	2000 / M1				→
Classification, electrical		E2, C1				→
Rated operating sequence		O - 3 min - CO - 3 min - CO				→
Number of short-circuit breaking operations	n	6 or 20				→

*) 21 kA at 60 Hz

1) 25 kA in preparation

2) 20 kA in preparation

Room planning

Please observe the following for room planning and switchgear installation:

Switchgear installation

Wall-standing arrangement

- 1 row
- 2 rows (for face-to-face arrangement)

Option: Free-standing arrangement

- Switchgear dimensions
- Floor openings: For dimensions, see pages 67 to 70
- Direction of pressure relief and the associated relief rooms.

Pressure relief

In the standard design, the pressure is relieved downwards. In the case of non-extendable panel blocks with an overall height of 1400 and 1700 mm and wall-standing arrangement, the pressure can optionally be relieved to the rear.

For room dimensions, see the dimension drawings below; for the internal arc classification according to IEC / EN 62271-200 / VDE 0671-200, the room height of accessible switchgear rooms results from the switchgear height of +600 mm (± 100 mm).

The door dimensions depend on

- the number of panels in one transport unit
- the switchgear design with or without low-voltage compartment.

Switchgear fixing

- For floor openings and fixing points of the switchgear, see pages 67 to 70
- Foundations:
 - Steel girder construction
 - Reinforced-concrete floor.

For panel dimensions, see pages 9, 10 and 55 to 65.

Weight, for data, see page 72.

Switchgear installation with pressure relief downwards

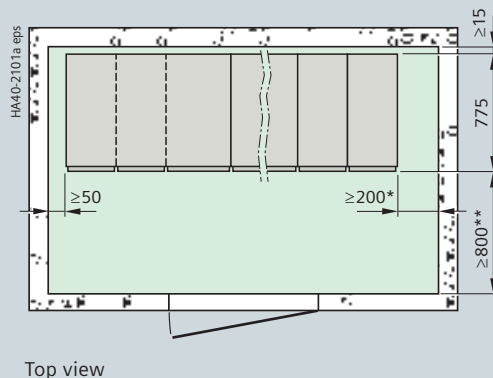
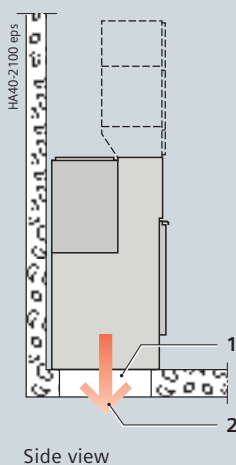

- *) For lined up switchgear
- **) Depending on national requirements. For extension or panel replacement, a control aisle of at least 1000 mm is recommended

Switchgear installation with pressure relief downwards or to the rear (option)

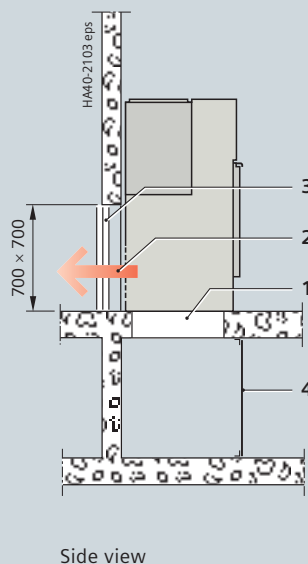
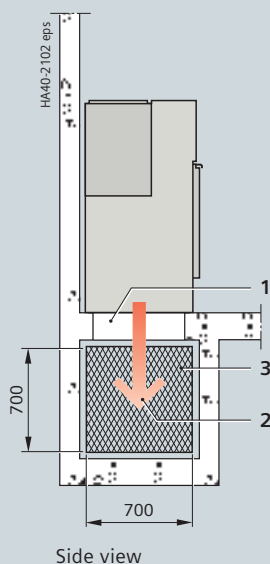

- 1 Floor opening
- 2 Direction of pressure relief
- 3 Expanded metal (supplied by site)
- 4 Partition (e.g. made of metal, supplied by site)

Technical Data

Switchgear installation

Room planning

Switchgear installation with rear pressure relief duct (option) for switchgear blocks with IAC A FL up to 16 kA/1 s

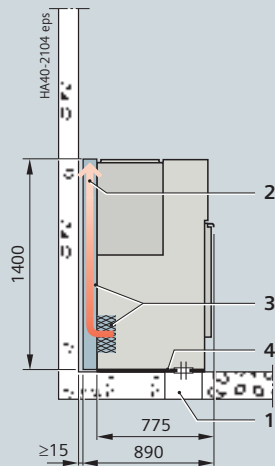

Side view

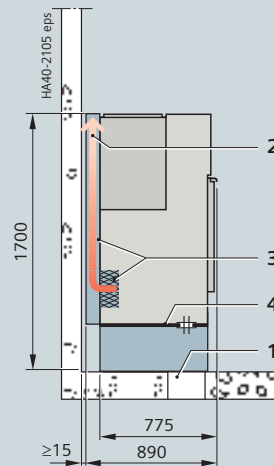

Side view

- 1 Floor opening
- 2 Direction of pressure relief
- 3 Pressure absorber system with pressure relief duct directed upwards at the rear
- 4 Divided floor cover for cable insertion, local installation

Switchgear installation with base and rear pressure relief duct (option) for switchgear with IAC A FL or FLR up to 21 kA/1 s

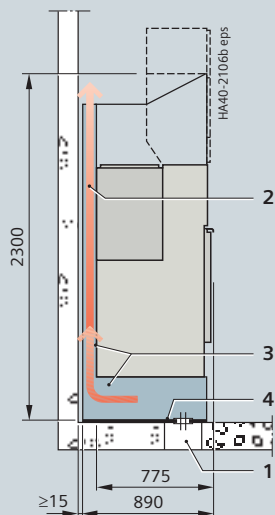

Side view

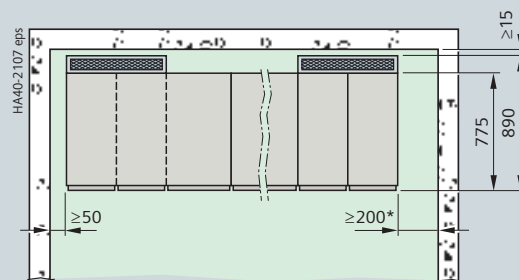

Top view

*) For lined up switchgear

Room heights of switchgear installation with rear pressure relief duct

Switchgear height	Room height
1400 mm	≥ 2000 mm
1700 mm	≥ 2200 mm
2300 mm	≥ 2400 mm

Product Range

Product range overview of preferred scheme versions in block-type construction

Scheme	Installation dimensions		
	Width mm	Depth mm	Height mm
Components shown in dotted lines can be used optionally.			

Scheme	Installation dimensions		
	Width mm	Depth mm	Height mm
Components shown in dotted lines can be used optionally.			

Switchgear blocks with transformer feeders, optionally with busbar extension

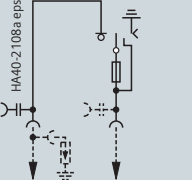
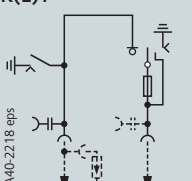
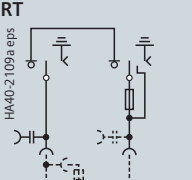
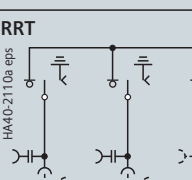
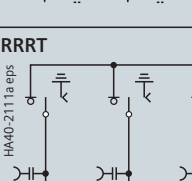
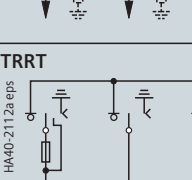
KT 	K Radial cable connection as incoming feeder	1 transformer feeder, 1 radial cable connection		
		740	775	1200 1400 1700
K(E)T 	K Radial cable connection as incoming feeder	1 transformer feeder, 1 radial cable connection with make-proof earthing switch		
		860	775	1200 1400 1700
RT 		1 ring-main feeder, 1 transformer feeder		
		740	775	1200 1400 1700
RRT 		2 ring-main feeders, 1 transformer feeder		
		1050	775	1200 1400 1700
RRRT 		3 ring-main feeders, 1 transformer feeder		
		1360	775	1200 1400 1700
TRRT 		2 ring-main feeders, 2 transformer feeders		
		1480	775	1200 1400 1700

Switchgear blocks with circuit-breaker feeders, optionally with busbar extension

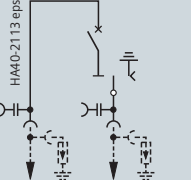
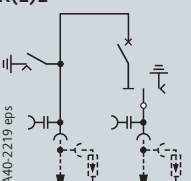
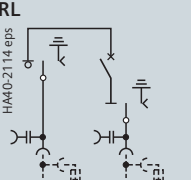
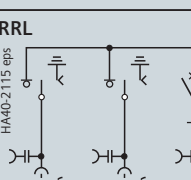
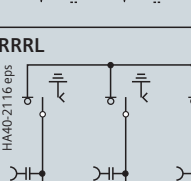
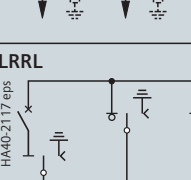
KL 	K Radial cable connection as incoming feeder	1 circuit-breaker feeder, 1 radial cable connection		
		740	775	1200 1400 1700
K(E)L 	K Radial cable connection as incoming feeder	1 circuit-breaker feeder, 1 radial cable connection with make-proof earthing switch		
		860	775	1200 1400 1700
RL 		1 ring-main feeder, 1 circuit-breaker feeder		
		740	775	1200 1400 1700
RRL 		2 ring-main feeders, 1 circuit-breaker feeder (type 2)		
		1050	775	1200 1400 1700
RRRL 		3 ring-main feeders, 1 circuit-breaker feeder (type 2)		
		1360	775	1200 1400 1700
LRRL 		2 ring-main feeders, 2 circuit-breaker feeders (type 2)		
		1480	775	1200 1400 1700

Product Range

Product range overview of preferred scheme versions in block-type construction

Scheme Components shown in dotted lines can be used optionally.	Installation dimensions		
	Width mm	Depth mm	Height mm

Scheme Components shown in dotted lines can be used optionally.	Installation dimensions		
	Width mm	Depth mm	Height mm

Switchgear blocks with ring-main feeders, optionally with busbar extension

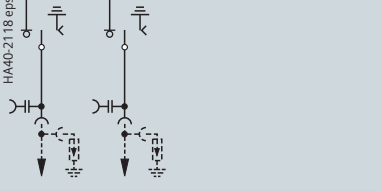
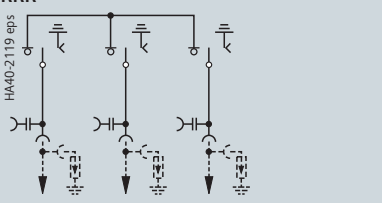
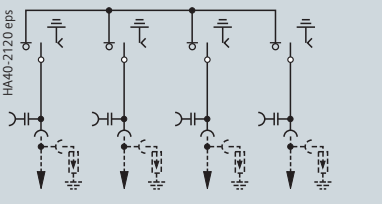
RR 	2 ring-main feeders		
		620	775
RRR 	3 ring-main feeders		
		930	775
RRRR 	4 ring-main feeders		
		1240	775

Switchgear blocks with transformer feeders, optionally with busbar extension

TT 	2 transformer feeders		
		860	775
TTT 	3 transformer feeders		
		1290	775

Product Range

Individual panels and modules – freely configurable for up to 4 functions in the block

Cable feeder

HA40-2125 eps

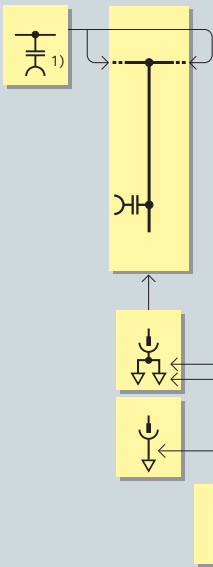

Type K ²⁾
310 mm wide
Type K(E) ²⁾
430 mm wide
with make-proof
earthing switch

Ring-main feeder

HA40-2124 eps

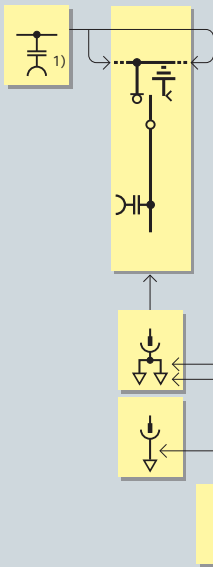

Type R
310 mm wide

Transformer feeder

HA40-2126a eps

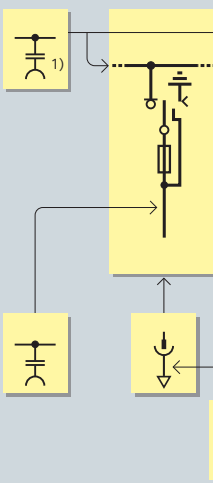

Type T
430 mm wide

4MC7031

Circuit-breaker feeder

HA40-2127 eps

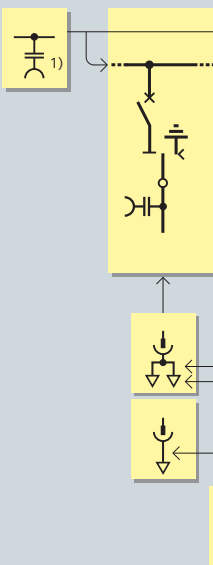

Type L
430 mm wide

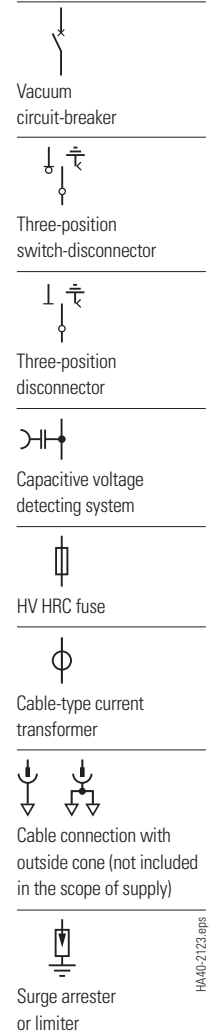

HA40-2123 eps

- 1) Only for end panel, on the free connection side of the busbar
- 2) Only as individual panel and in 2-panel blocks

Product Range

Individual panels and modules

Bus sectionalizer panel / module (with switch-disconnector) only on the right in panel blocks with switch-disconnector

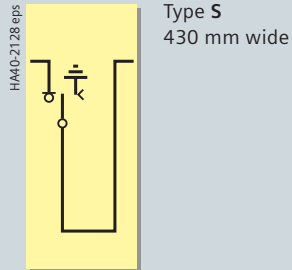

with switch-disconnector / fuse combination

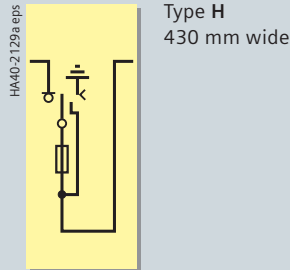

Bus sectionalizer panel with switch-disconnector

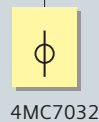
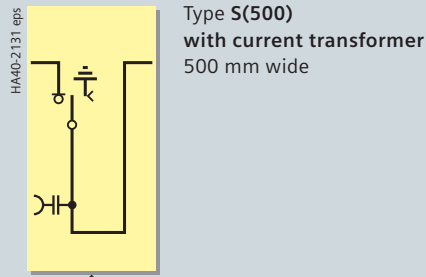
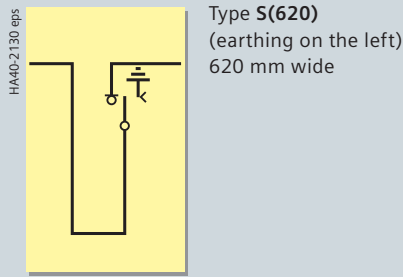

Bus sectionalizer panel with circuit-breaker

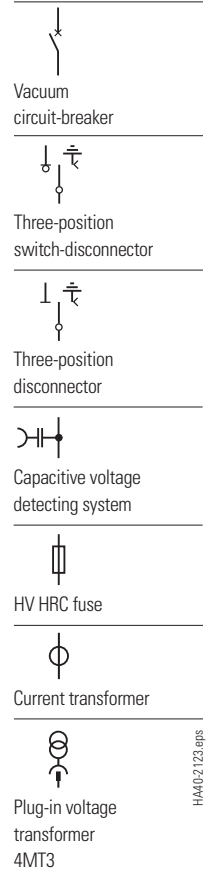
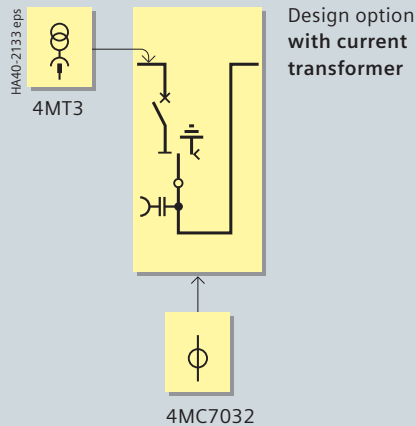
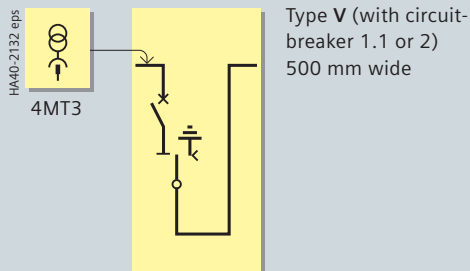

HA40-2123 eps

Product Range

Individual panels

Ring-main feeder

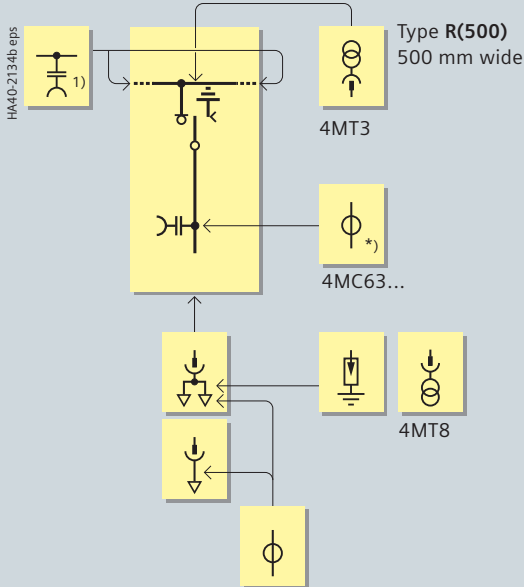

Circuit-breaker feeder

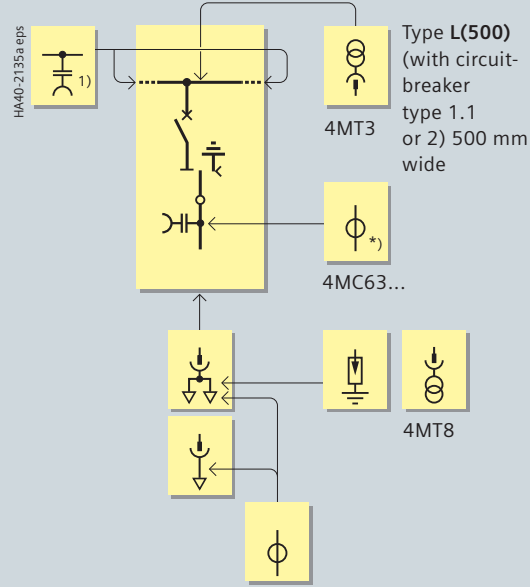

Busbar earthing panel

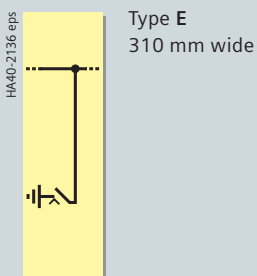

Busbar voltage metering panel

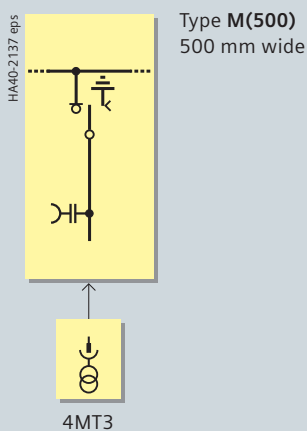

Busbar earthing panel

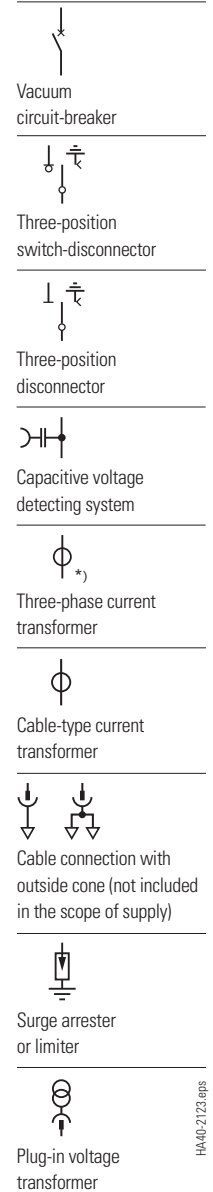
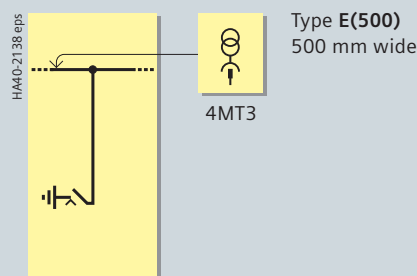

HA40-2123 eps

1) Only for end panel, on the free connection side of the busbar

Ring-main feeder

Type R

Section

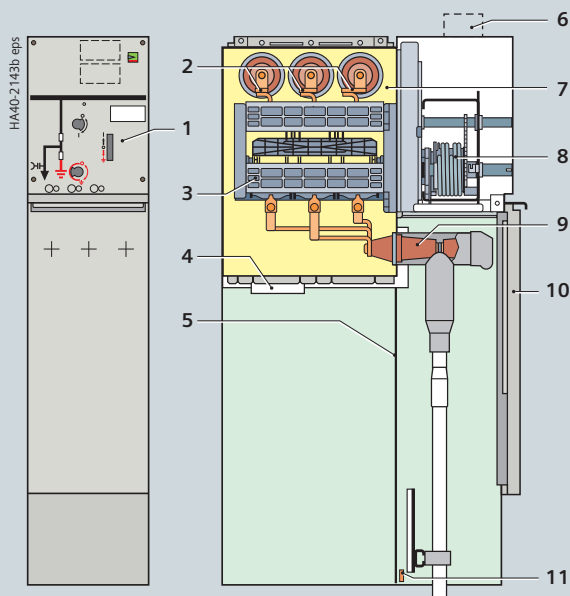

Transformer feeder

Type T

Section

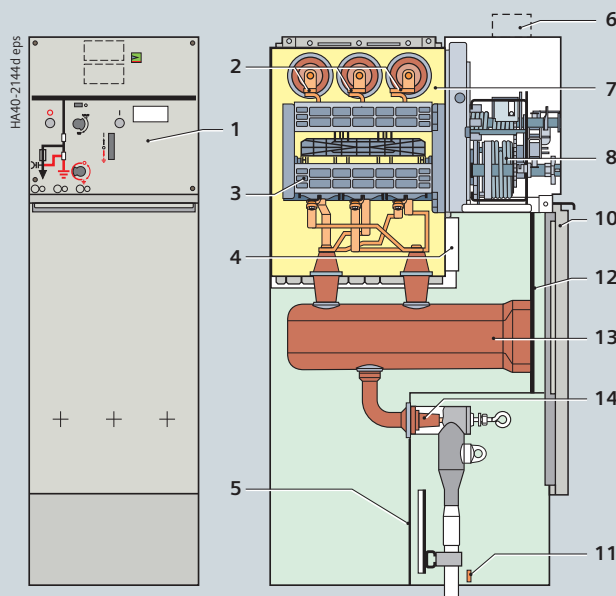

Circuit-breaker feeder

Type L

Section

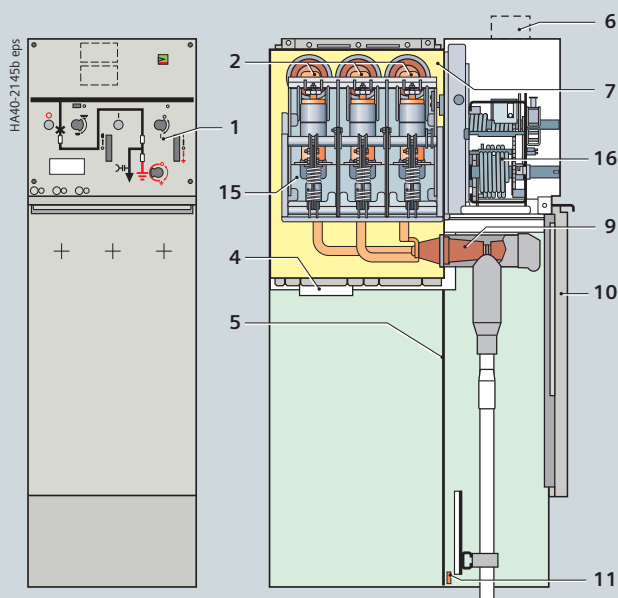

1 Control board (for details, see page 20)

2 Busbar arrangement

3 Three-position switch-disconnector

4 Pressure relief device

5 Partition plate between cable compartment and pressure relief compartment

6 Wiring duct, removable, for protection and / or bus wires

7 Switchgear vessel, filled with gas

8 Operating mechanism of switching device

9 Bushing for cable plug with bolted contact (M16)

10 Cable compartment cover

11 Earthing busbar with earthing connection

12 Partition

13 HV HRC fuse assembly

14 Bushing for cable plug with plug-in contact

15 Vacuum circuit-breaker

16 Circuit-breaker operating mechanism, operating mechanism for three-position disconnector

Design

Panel design (examples)

Circuit-breaker feeder

Type L500

Section

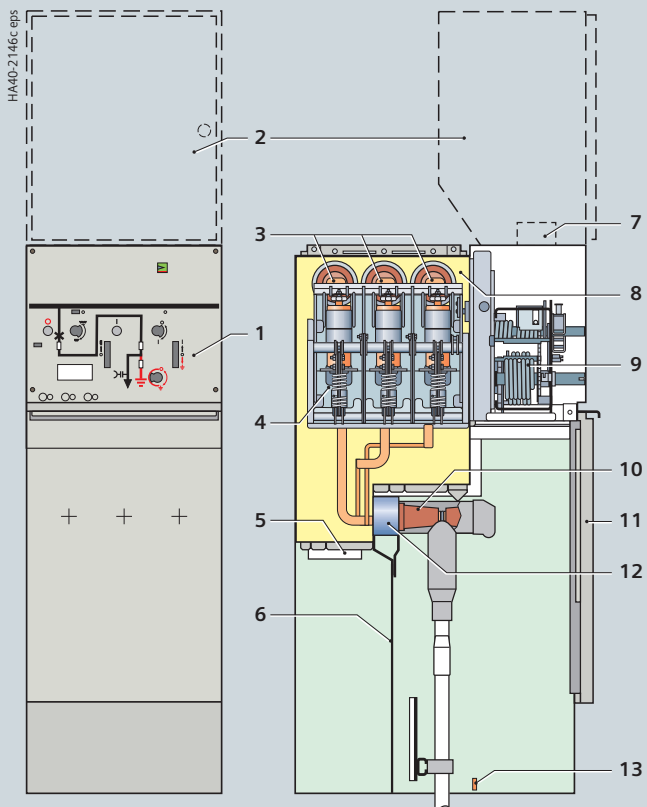

- 1 Control board (for details, see page 20)
- 2 Option: Low-voltage compartment
- 3 Busbar arrangement
- 4 Vacuum circuit-breaker
- 5 Pressure relief device
- 6 Partition plate between cable compartment and pressure relief compartment
- 7 Wiring duct, removable, for protection and / or bus wires
- 8 Switchgear vessel, filled with gas
- 9 Operating mechanism of switching device
- 10 Bushing for cable plug with bolted contact (M16)
- 11 Cable compartment cover
- 12 Option: Three-phase current transformer (protection transformer)
- 13 Earthing busbar with earthing connection

Type 2

Section

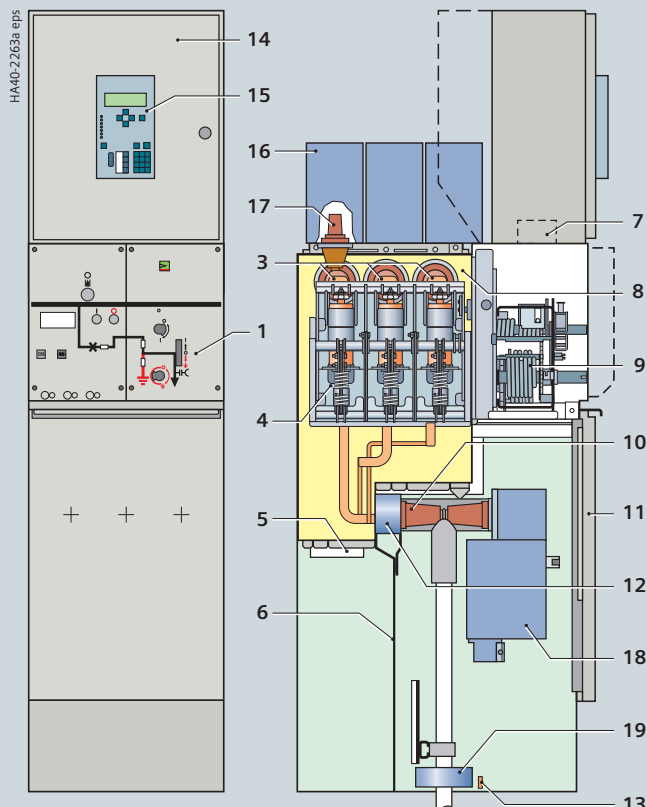

- 14 Low-voltage compartment (standard) for vacuum circuit-breaker
- 15 Option: SIPROTEC bay controller
- 16 Option: Plug-in voltage transformer type 4MT3 on the busbar
- 17 Bushing for connection of plug-in voltage transformers
- 18 Option: Plug-in voltage transformer 4MT8 at the connection
- 19 Cable-type current transformer

Type 1.1

Billing metering panel

Type M, air-insulated

HA40-2148d-eps

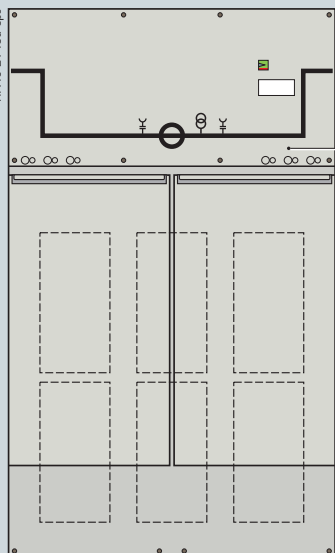

Section

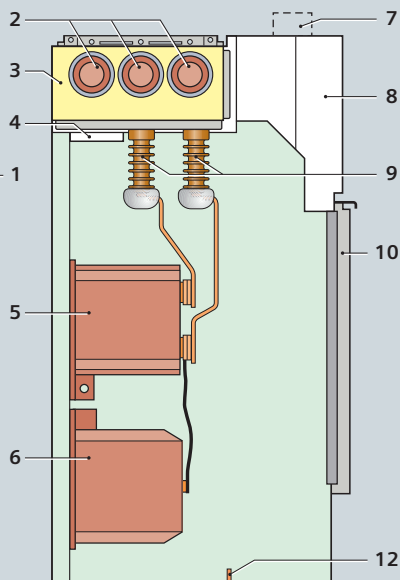

Connection: Busbar – busbar

Section

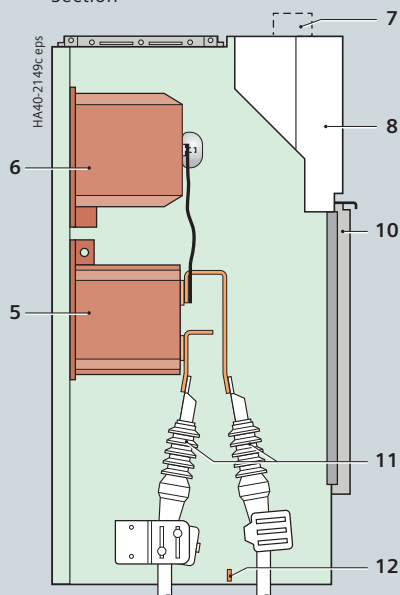

Connection: Cable – cable

- 1 Sockets for voltage detecting system
- 2 Busbar connection
- 3 Busbar vessel, filled with gas
- 4 Pressure relief device
- 5 Current transformer type 4MA7
- 6 Voltage transformer type 4MR
- 7 Wiring duct, removable, for protection and / or bus wires
- 8 Niche for customer-side low-voltage equipment, hinged cover
- 9 Bushings for connection of transformer bars
- 10 Transformer compartment cover
- 11 Cable connection
- 12 Earthing busbar with earthing connection

Design

Operation (examples)

The control boards are function-related. They integrate operation, mimic diagram and position indication. Furthermore, indicating, measuring and monitoring equipment as well as locking devices and local-remote switches are arranged according to the panel type and version. The ready-for-service indicator and rating plates are fitted in accordance with the panel blocks.

Operation is identical for transformer and circuit-breaker feeders. First, the operating mechanism must be charged; then, closing/opening is done through separate pushbuttons. The condition of the energy store is indicated.

All actuating openings are functionally interlocked against each other, and are optionally lockable. Separate operating levers for the disconnecting and earthing function are optionally available.

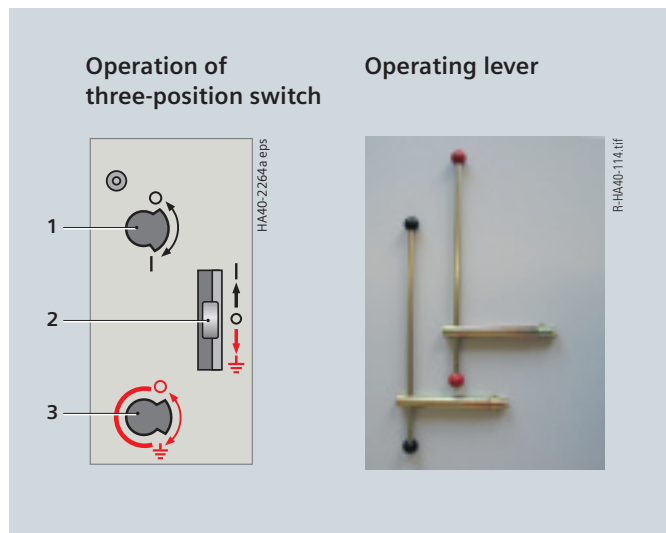

- 1 Manual operation of load-break function
- 2 Locking function (option for ring-main feeders)
- 3 Manual operation of earthing function
- 4 Rating plate
- 5 Position indicator for switch-disconnector
- 6 Position indicator for earthing switch
- 7 Sockets of capacitive voltage detecting system
- 8 "Fuse tripped" indicator
- 9 ON pushbutton for transformer or circuit-breaker function
- 10 OFF pushbutton for transformer or circuit-breaker function
- 11 Manual spring charging
- 12 "Spring charged" indicator
- 13 Position indicator for circuit-breaker

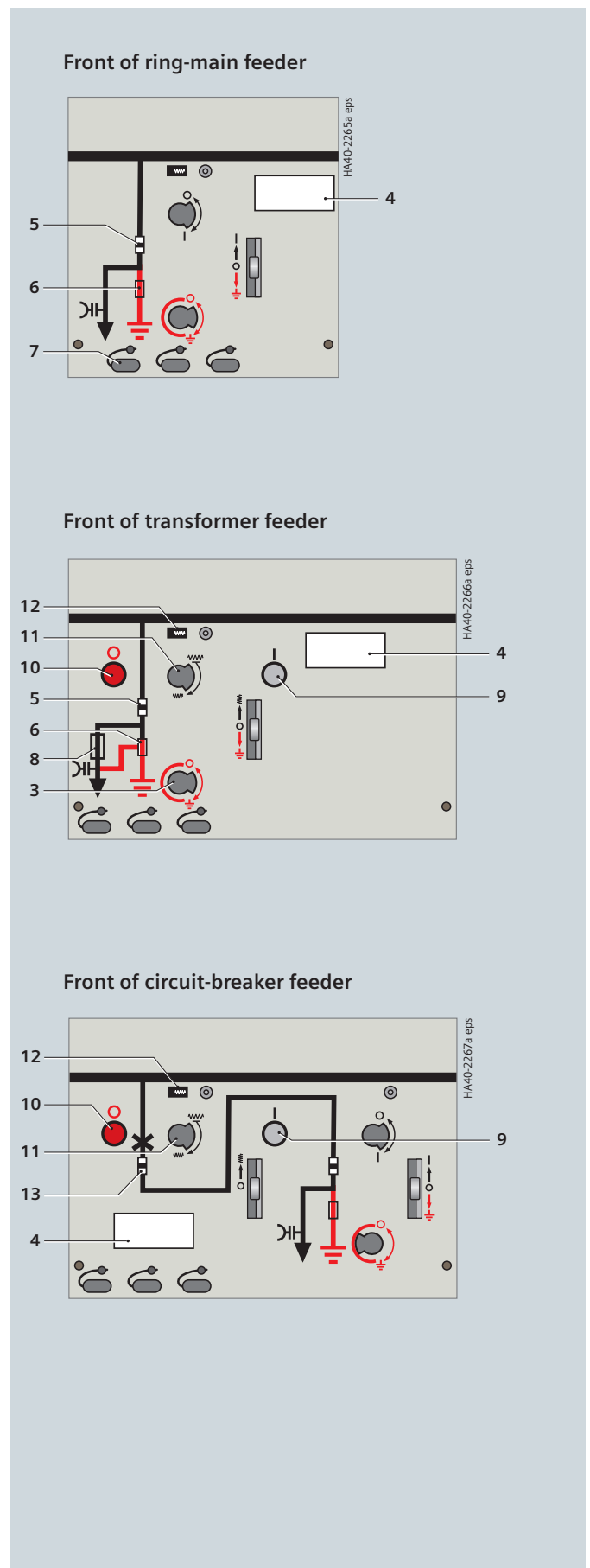

Features

- Switch positions:
CLOSED – OPEN – EARTHED
- Switching functions as general-purpose switch-disconnector (class E3) according to
 - IEC/EN 60265-1/VDE 0670-301
 - IEC/EN 62271-102/VDE 0671-102
- Designed as a three-position switch with the functions
 - Switch-disconnector and
 - Make-proof earthing switch
- Operation via rotary bushing welded gas-tight into the front of the switchgear vessel
- Climate-independent contact in the gas-filled switchgear vessel
- Maintenance-free according to IEC/EN 62271-1/VDE 0671-1
- Individual secondary equipment.

Mode of operation

The operating shaft forms one unit together with the three contact blades. Due to the arrangement of the fixed contacts (earth – busbar), it is not necessary to interlock the CLOSE and EARTHING functions.

Closing operation

During the closing operation, the operating shaft with the moving contact blades changes from the "OPEN" to the "CLOSED" position.

The force of the spring-operated mechanism ensures a high, independent of the user, closing speed and a reliable connection of the main circuit.

Opening operation

During the opening operation, the arc is caused to rotate by the arc-suppression system. This rotation movement prevents the development of a fixed root.

The isolating distance in gas established after breaking fulfills the conditions applicable to isolating distances in accordance with

- IEC/EN 62271-102/VDE 0671-102
- and
- IEC/EN 62271-1/VDE 0671-1.

Due to the arc rotation caused by the arc-suppression system, both load currents and minor no-load currents are safely interrupted.

Earthing operation

The EARTHING operation is implemented by changing from the "OPEN" to the "EARTHED" position.

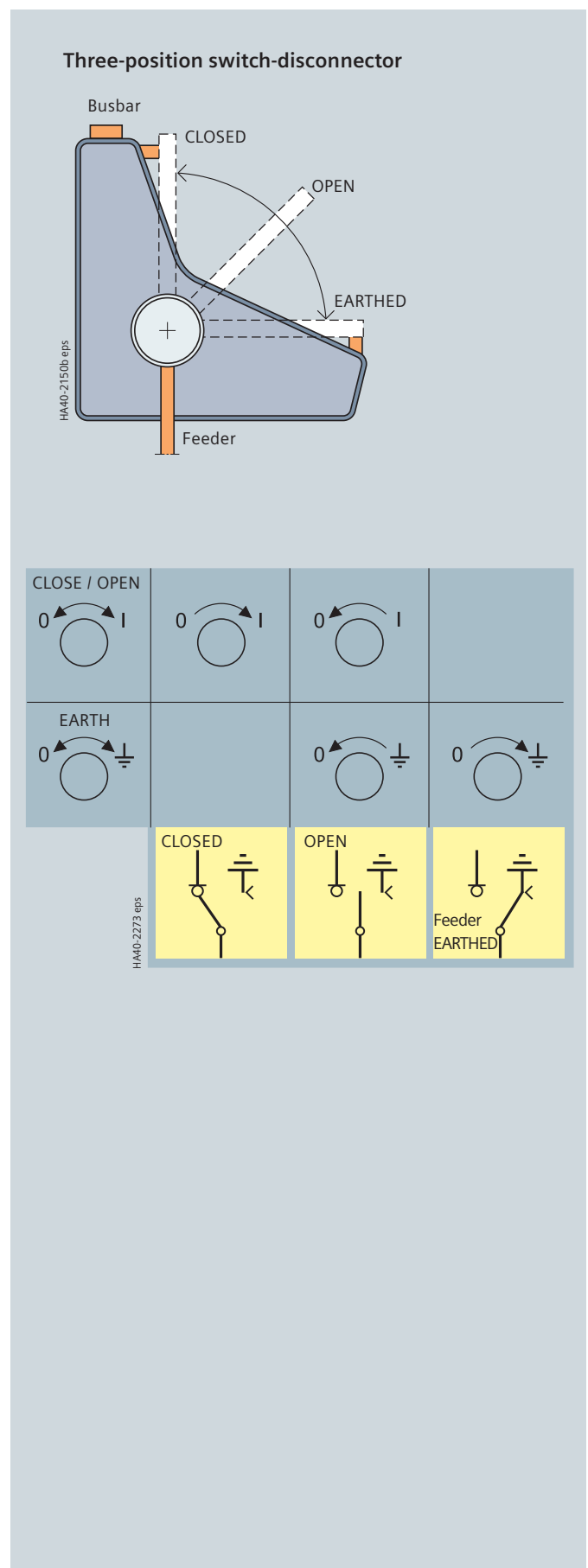

Components

Operating mechanisms for the three-position switch

Features

- Mechanical endurance of more than 1000 operating cycles
- Parts subjected to mechanical stress are made of non-rusting materials
- Manual operation with the help of a slip-on operating lever
- Option: Motor operation
- Control board with accordingly cut-out switching gate prevents the three-position switch-disconnector from being switched directly from the "CLOSED" via the "OPEN" to the "EARTHED" position.
- Two separate actuating openings are provided for unambiguous selection of the DISCONNECTING and EARTHING functions.
- Operation via rotary movement, operating direction according to recommendation of VDN / VDEW.

Spring-operated mechanism

The switching movements are performed independently of the operating speed.

Spring-operated / stored-energy mechanism

The switching movements are performed independently of the operating speed.

During the charging process, the closing and opening springs are charged. This ensures that the switch-disconnector / fuse combination can switch off all types of faults reliably even during closing.

Closing and opening is done via pushbuttons, and is therefore identical with the operation of circuit-breaker operating mechanisms.

An energy store is available for tripping by means of an operating HV HRC fuse or via a shunt release (f-release).

After tripping, a red bar appears on the position indicator.

Assignment of operating mechanism type of three-position switch to panel types

Panel type	R, S, L		T, H	
Function	Switch-disconnector (R, S) Disconnecter (L)	Earthing switch	Switch-disconnector	Earthing switch
Type of operating mechanism	Spring-operated	Spring-operated	Stored-energy	Spring-operated
Operation	Manual Motor (option)	Manual	Manual Motor (option)	Manual

Operating mechanisms for the three-position switch, equipment (optional)

Motor operating mechanism (option)

The manual operating mechanisms of 8DJH switchgear can be equipped with motor operating mechanisms for the three-position switch-disconnector. Retrofitting is possible.

Operating voltages for motor operating mechanisms:

- 24, 48, 60, 110, 220 V DC
- 110 and 230 V AC, 50 / 60 Hz.

Operation:

- Local operation by momentary-contact rotary control switch (option)
- Remote operation (standard) applied to terminal.

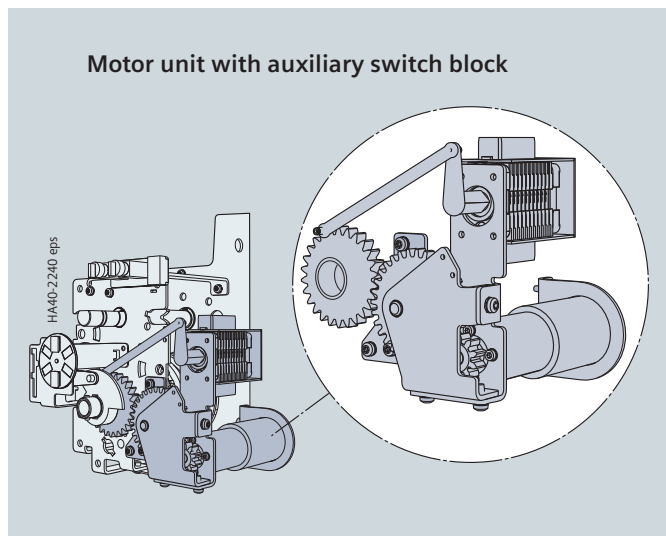

Motor unit with auxiliary switch block

Shunt release (option) (f-release)

Spring-operated / stored-energy mechanisms can be equipped with a shunt release. Remote electrical tripping of the three-position switch-disconnector is possible via the magnet coil of the shunt release, e.g. transformer overtemperature tripping.

To avoid thermal overloading of the shunt release in the event of a continuous signal that may be applied, the shunt release is switched off via an auxiliary switch which is mechanically coupled with the three-position switch-disconnector.

Auxiliary switch (option)

Each operating mechanism of the three-position switch-disconnector can be optionally equipped with an auxiliary switch for the position indication:

- Switch-disconnector function:
CLOSED and OPEN: 1 NO + 1 NC + 2 changeover
- Earthing switch function:
CLOSED and OPEN: 1 NO + 1 NC + 2 changeover.

Technical data of the auxiliary switch

Breaking capacity

AC operation at 40 Hz up to 60 Hz		DC operation	
Operating voltage	Normal current	Operating voltage	Normal current Resistive Inductive, T = 20 ms
V	A	V	A A
up to 230	10	24	10 10
		48	10 9
		60	9 7
		110	5 4
		240	2.5 2

Rated switching capacity

Rated insulation voltage	250 V AC / DC
Insulation group	C acc. to VDE 0110
Continuous current	10 A
Making capacity	50 A

Abbreviations:

NO = Normally open contact
NC = Normally closed contact

Components

Vacuum circuit-breaker

Features

- The vacuum circuit-breaker consists of a vacuum interrupter unit with integrated three-position disconnecter located in the switchgear vessel, and the associated operating mechanisms.
- According to IEC/EN 62271-100/VDE 0671-100
- Application in hermetically welded switchgear vessel in conformity with the system
- Climate-independent vacuum interrupter poles in the gas-filled switchgear vessel
- Operating mechanism located outside the switchgear vessel in the front operating mechanism box
- Maintenance-free for indoor installation according to IEC/EN 62271-1/VDE 0671-1
- Individual secondary equipment.

Operating mechanism functions

The closing spring is charged by means of the operating lever or the hand crank supplied, or by the motor (option), until the latching of the closing spring is indicated ("spring charged" indicator). Then, the vacuum circuit-breaker can be closed manually or electrically.

In operating mechanisms provided for automatic reclosing (ARE), the closing spring can be recharged by hand or automatically in case of motor operating mechanism. Thus, the "closing option" is available again.

Operating mechanism

The operating mechanism assigned to a circuit-breaker feeder consists of the following components:

- Operating mechanism for circuit-breaker
- Operating mechanism for three-position disconnecter
- Motor operating mechanism (optional)
- Position indicators
- Pushbuttons for CLOSING and OPENING the circuit-breaker
- Operations counter (optional)
- Interlocking between circuit-breaker and disconnecter.

Assignment of operating mechanism type

Panel type	L, V		
Function	Circuit-breaker	Three-position disconnecter	
		Disconnecter	Earthing switch
Type	Stored-energy	Spring-operated	Spring-operated
Operation	Manual / motor	Manual / motor	Manual

Trip-free mechanism

The vacuum circuit-breaker is fitted with a trip-free mechanism according to IEC/EN 62271-100/VDE 0671-100. In the event of an opening command being given after a closing operation has been initiated, the moving contacts return to the open position and remain there even if the closing command is sustained. This means that the contacts are momentarily in the closed position, which is permissible according to the above-mentioned standard.

Circuit-breaker

Circuit-breaker	Type 1.1	Type 2
Short-circuit breaking current	up to 25 kA	up to 20 kA *)
Rated operating sequence		
O - 0.3 s - CO - 3 min - CO	•	–
O - 3 min - CO - 3 min - CO	–	•
Number of breaking operations I_r	10 000	2 000
Number of short-circuit breaking operations I_{SC}	up to 50	up to 20
In individual panel	430 mm	•
	500 mm	•
In panel block	430 mm	•

Explanations:

- Design option
 - Not available
- *) Up to 21 kA at 60 Hz

Electrical service life

Vacuum circuit-breaker type 2

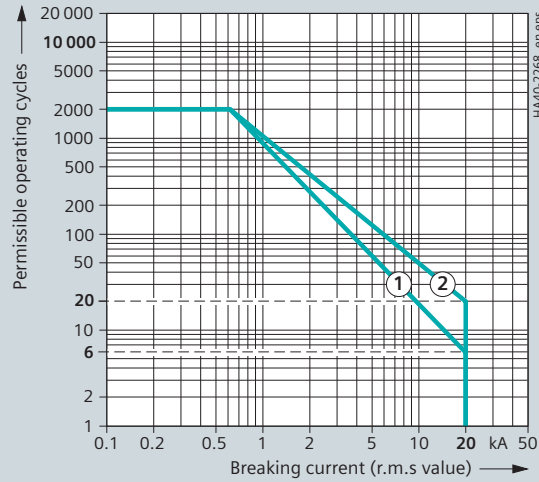

Rated voltage 12 kV

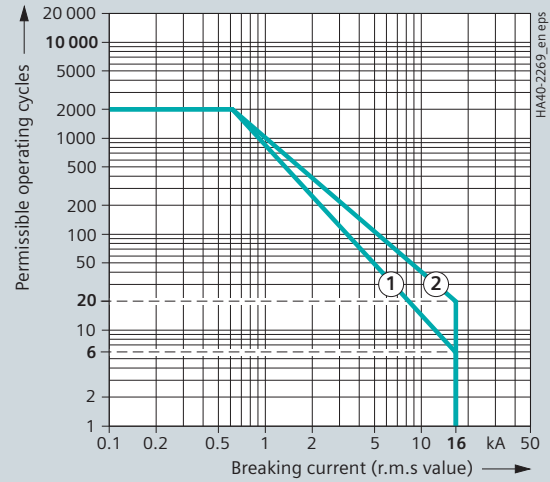

Rated voltage 24 kV

Vacuum circuit-breaker type 1.1

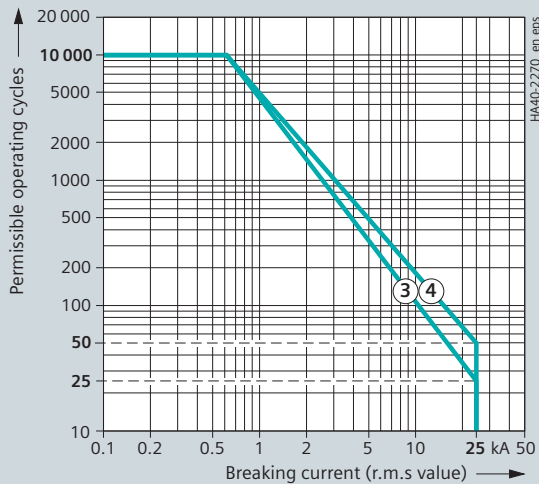

Rated voltage 12 kV

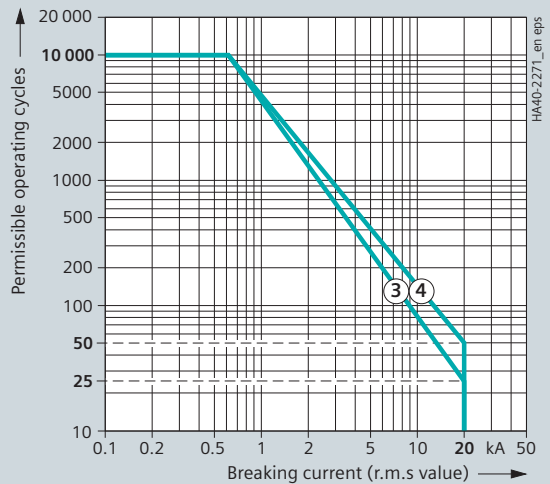

Rated voltage 24 kV

Max. number of short-circuit breaking operations

- ① n = 6 ③ n = 25
- ② n = 20 ④ n = 50

Components

Secondary equipment of the vacuum circuit-breakers

Motor operating mechanism (option)

Operating voltages for motor operating mechanisms:

- 24, 48, 60, 110, 220 V DC
- 110 and 230 V AC, 50/60 Hz.

Further values on request.

Motor rating for circuit-breaker operating mechanism type 1.1 at

24 V to 220 V DC: maximum 350 W

110 V and 230 V AC: maximum 400 VA.

Motor rating for disconnecter operating mechanism and circuit-breaker operating mechanism type 2 at

DC: maximum 80 W

AC: maximum 80 VA.

Secondary components

The scope of the secondary equipment of the vacuum circuit-breaker depends on the type of application and offers a wide range of possible variations, allowing almost every requirement to be satisfied.

Closing solenoid (option for type 2)

- For electrical closing.

Shunt release

- Magnet coil for tripping by protection device or electrical actuation.

C.t.-operated release

- For tripping pulse 0.1 Ws in conjunction with suitable protection systems, e.g. protection system 7SJ45 or make Woodward/SEG type WIC; other designs on request
- Used if external auxiliary voltage is missing, tripping via protection relay.

Low-energy magnetic release only for type 2

- For tripping pulse 0.01 Ws, tripping via transformer monitor (IKI-30).

Undervoltage release

- Comprising:
 - Energy store and unlatching mechanism
 - Electromagnetic system, which is permanently connected to voltage while the vacuum circuit-breaker is closed; tripping is initiated when this voltage drops.

Anti-pumping (standard for type 1.1) (mechanical and electrical)

- Function: If constant CLOSE and OPEN commands are present at the vacuum circuit-breaker at the same time, the vacuum circuit-breaker will return to the open position after closing. It remains in this position until a new CLOSE command is given. In this manner, continuous closing and opening (= pumping) is avoided.

Circuit-breaker tripping signal (option for type 2)

- For electrical signaling (as pulse > 10 ms), e.g. to remote control systems, in the case of automatic tripping (e.g. protection)
- Via limit switch and cutout switch.

Varistor module

- To limit overvoltages to approx. 500 V for protection devices (when inductive components are mounted in the vacuum circuit-breaker)
- For auxiliary voltages ≥ 60 V DC.

Auxiliary switch

- Standard: 6 NO + 6 NC,
free contacts thereof
1 NO + 3 NC + 2 changeover
- Option (type 1.1): 12 NO + 12 NC,
free contacts thereof
7 NO + 4 NC + 2 changeover.

Position switch

- For signaling "closing spring charged".

Mechanical interlock

- Dependent on the type of operating mechanism
- Interrogation of the three-position disconnecter from the switchgear side
- Option: Operating mechanism with mechanical interlocking as
 - Stored-energy mechanism with closing solenoid and pushbutton: The pushbutton operated by the mechanical interlock prevents a continuous command to the closing solenoid
- During operation of the three-position disconnecter from CLOSED to OPEN, the vacuum circuit-breaker cannot be closed.

Components

Secondary equipment of the vacuum circuit-breakers

Vacuum circuit-breaker type 2

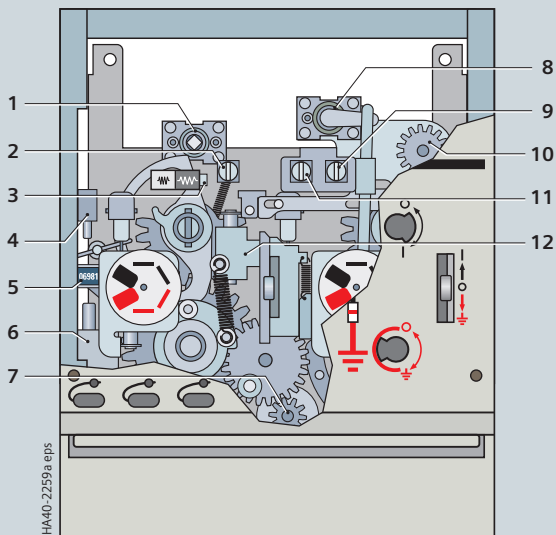

Vacuum circuit-breaker type 1.1

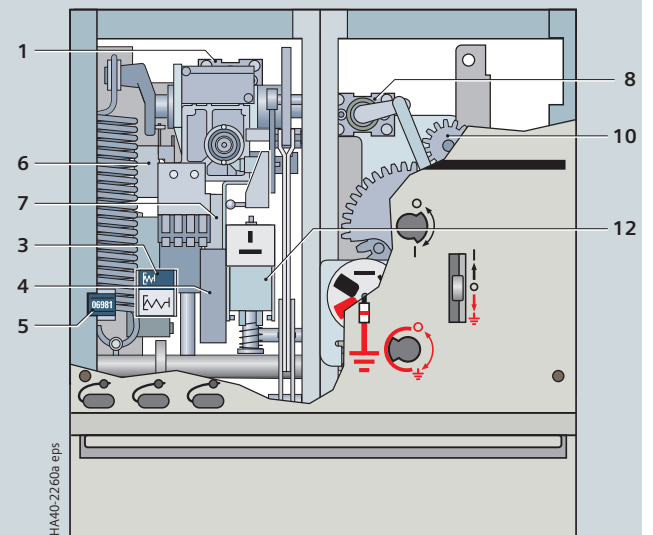

Maximum secondary equipment

- 1 Auxiliary switch at the circuit-breaker
- 2 Knob-operated switch, el. CLOSE / OPEN, circuit-breaker
- 3 Position switch "spring charged"
- 4 2nd release
- 5 Operations counter
- 6 1st release

- 7 Motor operating mechanism, circuit-breaker
- 8 Auxiliary switch at the three-position disconnecter
- 9 Knob-operated switch, el. CLOSE / OPEN, three-position switch
- 10 Motor operating mechanism, three-position disconnecter
- 11 Knob-operated switch, local / remote
- 12 Closing solenoid, circuit-breaker

Components

Busbar extension, modularity

Features

- Busbar extension possible on all individual panels and panel blocks (ordering option)
- Plug-in unit consisting of contact coupling and screened silicone coupling
- Insensitive to pollution and condensation
- Switchgear installation, extension or panel replacement is possible without gas work
- Busbar connections to metering panels are possible.

Every switchgear block and every individual panel is optionally available with busbar extension on the right, on the left or on both sides. This offers a high flexibility for the creation of switchgear configurations the functional units of which are lined up in any order. Local installation and lining up is done without gas work.

Lining up takes place as follows:

- By the busbar couplings on the medium-voltage side. Tolerances between adjacent panels are compensated by spherical fixed contacts and the movable contact coupling with degrees of freedom in all axis directions.
- By safe dielectric sealing with screened silicone couplings that are externally earthed and adjustable to tolerances. These silicone couplings are pressed on with a defined pressure when the panels are interconnected.
- On free busbar ends, screened dummy plugs are inserted, each of which is pressed on through a metal cover. A common protective cover with a warning is fixed over all three covers.
- By centering bolts for easier switchgear installation and fixing of adjacent panels.
- By bolted panel joints with defined stops for the distances between adjacent panels and the associated pressure for contact pieces and silicone couplings.

Switchgear installation, extension or replacement of one or more functional units requires a lateral wall distance ≥ 200 mm.

Interconnecting the panels

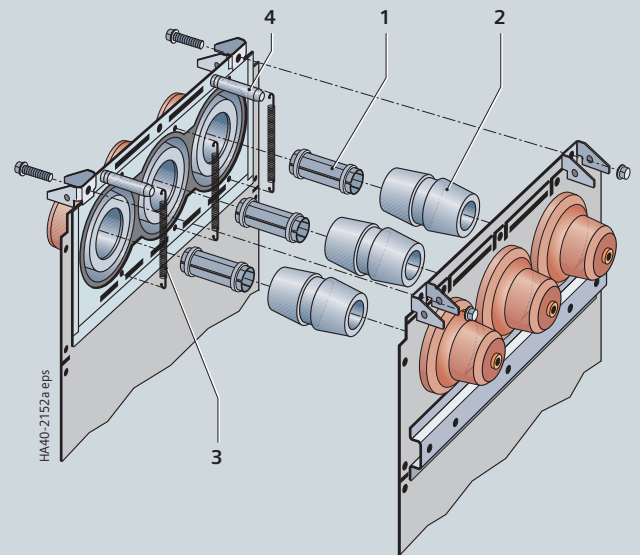

Surge-proof termination

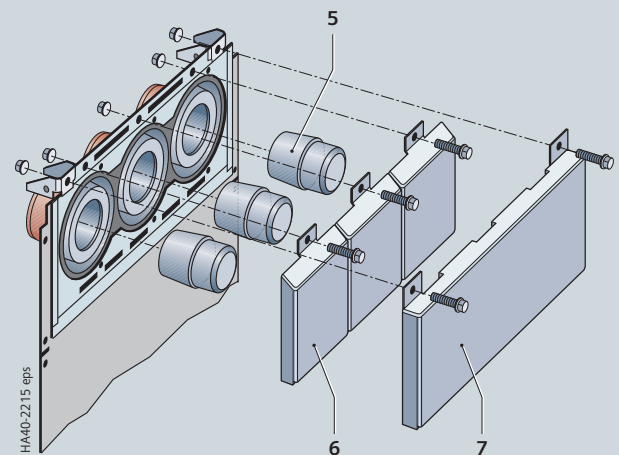

- 1 Contact piece
- 2 Silicone coupling
- 3 Tension spring for earthing
- 4 Centering bolt
- 5 Silicone dummy plug with insertable sleeve
- 6 Clamping cover for dummy plugs
- 7 Busbar termination cover

Components

HV HRC fuse assembly

Features

- Application in switch-disconnector / fuse combination in
 - Transformer feeders (T)
 - Bus sectionalizer with switch-disconnector (H)
 - HV HRC fuse-links according to DIN 43625 (main dimensions) with striker; "medium" version according to IEC / EN 60282-1 / VDE 0670-4
 - As short-circuit protection for transformers
 - With selectivity – depending on correct selection – to upstream and downstream connected equipment
 - 1-pole insulated
 - Requirements according to IEC / EN 62271-105 / VDE 0671-105 fulfilled in high-voltage switch-fuse combinations
 - Climate-independent and maintenance-free
 - Fuse assembly connected to the three-position switch-disconnector via welded-in bushings and connecting bars
 - Arrangement of fuse assembly below the switchgear vessel
 - Fuses can only be replaced if feeder is earthed
 - Fuse slide for reference dimension 292 mm and 442 mm
- Option with three-position switch-disconnector
- Shunt release (f-release)
 - "Tripped signal" of the transformer switch for remote electrical indication with 1 normally-open contact.

Mode of operation

In the event that an HV HRC fuse-link has tripped, the switch-disconnector is tripped via an articulation which is integrated into the cover of the fuse box (see figure).

In the event that the fuse tripping fails, e.g. if the fuse has been inserted incorrectly, the fuse box is protected by thermal protection. The overpressure generated by overheating trips the switch via the diaphragm in the cover of the fuse box and via an articulation. This prevents the fuse box from incurring irreparable damage.

This thermal protection works independently of the type and design of the HV HRC fuse used. Like the fuse itself, it is maintenance-free and independent of any outside climatic effects.

Furthermore, the HV HRC fuses (e.g. make SIBA) release the striker depending on the temperature and trip the switch-disconnector as early as in the fuse overload range.

Impermissible heating of the fuse box can be avoided in this way.

Replacement of HV HRC fuse-links (without tools)

- Isolate and earth the transformer feeder
- Open the cover of the fuse access
- Replace the HV HRC fuse-link.

HV HRC fuse assembly

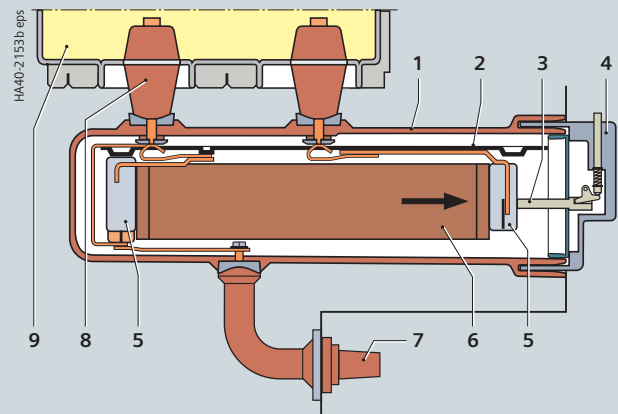

- 1 Fuse box
- 2 Fuse slide
- 3 Tripping pin for spring-operated / stored-energy mechanism
- 4 Sealing cover with seal
- 5 Locking cap
- 6 HV HRC fuse
- 7 Cable connection
- 8 Bushing
- 9 Switchgear vessel

Schematic sketches for fuse tripping

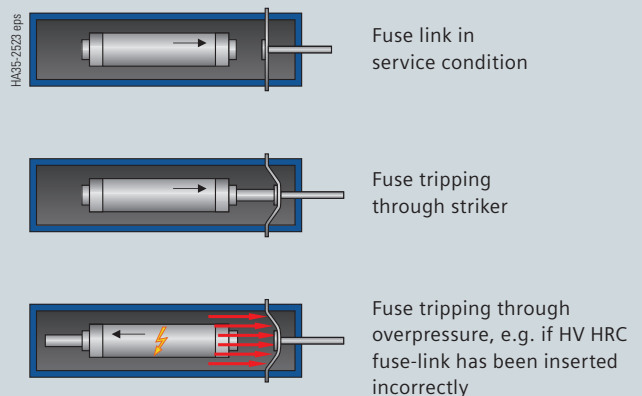

Components

Allocation of HV HRC fuses and transformer ratings

Allocation of HV HRC fuses and transformers

The following table shows the recommended HV HRC fuse-links make SIBA (electrical data valid for ambient air temperatures of up to 40 °C) for fuse protection of transformers.

Fuse protection table

The three-position switch-disconnector in the transformer feeder (transformer switch) was combined and tested with HV HRC fuse-links.

Standards

HV HRC fuse-links "medium" version with striker and for tripping energy 1 ± 0.5 Joule according to

- IEC / EN 60282-1 / VDE 0670-4
- IEC / EN 60787 / VDE 0670-402
- DIN 43625 main dimensions.

Operating voltage kV	Transformer			HV HRC fuse				Order No. Make SIBA
	Rated power S_N kVA	Relative impedance voltage u_k %	Rated current I_1 A	Rated normal current of fuse I_{fuse} A	Operating voltage U_{fuse} kV	Dimension e mm	Outside diameter d mm	
3.3 to 3.6	20	4	3.5	6.3	3 to 7.2	292	53	30 098 13.6,3
				10	3 to 7.2	292	53	30 098 13.10
	50	4	8.75	16	3 to 7.2	292	53	30 098 13.16
				20	3 to 7.2	292	53	30 098 13.20
	75	4	13.1	20	3 to 7.2	292	53	30 098 13.20
				25	3 to 7.2	292	53	30 098 13.25
	100	4	17.5	31.5	3 to 7.2	292	53	30 098 13.31,5
				40	3 to 7.2	292	53	30 098 13.40
125	4	21.87	31.5	3 to 7.2	292	53	30 098 13.31,5	
			40	3 to 7.2	292	53	30 098 13.40	
160	4	28	40	3 to 7.2	292	53	30 098 13.40	
			50	3 to 7.2	292	53	30 098 13.50	
200	4	35	50	3 to 7.2	292	53	30 098 13.50	
			63	3 to 7.2	292	67	30 099 13.63	
250	4	43.74	63	3 to 7.2	292	67	30 099 13.63	
			80	3 to 7.2	292	67	30 099 13.80	
4.16 to 4.8	20	4	2.78	6.3	3 to 7.2	292	53	30 098 13.6,3
				16	3 to 7.2	292	53	30 098 13.16
	50	4	6.93	16	3 to 7.2	292	53	30 098 13.16
				20	3 to 7.2	292	53	30 098 13.20
	75	4	10.4	20	3 to 7.2	292	53	30 098 13.20
				25	3 to 7.2	292	53	30 098 13.25
	100	4	13.87	20	3 to 7.2	292	53	30 098 13.20
				25	3 to 7.2	292	53	30 098 13.25
125	4	17.35	25	3 to 7.2	292	53	30 098 13.25	
			31.5	3 to 7.2	292	53	30 098 13.31,5	
160	4	22.2	31.5	3 to 7.2	292	53	30 098 13.31,5	
			40	3 to 7.2	292	53	30 098 13.40	
200	4	27.75	40	3 to 7.2	292	53	30 098 13.40	
			50	3 to 7.2	292	53	30 098 13.50	
250	4	34.7	50	3 to 7.2	292	53	30 098 13.50	
			63	3 to 7.2	292	67	30 099 13.63	
315	4	43.7	63	3 to 7.2	292	67	30 099 13.63	
			80	3 to 7.2	292	67	30 099 13.80	
5.0 to 5.5	20	4	2.3	6.3	3 to 7.2	292	53	30 098 13.6,3
				10	3 to 7.2	292	53	30 098 13.10
	50	4	5.7	16	3 to 7.2	292	53	30 098 13.16
				20	3 to 7.2	292	53	30 098 13.20
	75	4	8.6	16	3 to 7.2	292	53	30 098 13.16
				20	3 to 7.2	292	53	30 098 13.20
	100	4	11.5	16	3 to 7.2	292	53	30 098 13.16
				20	3 to 7.2	292	53	30 098 13.20
125	4	14.4	20	3 to 7.2	292	53	30 098 13.20	
			25	3 to 7.2	292	53	30 098 13.25	
160	4	18.4	31.5	3 to 7.2	292	53	30 098 13.31,5	
			40	3 to 7.2	292	53	30 098 13.40	
200	4	23	40	3 to 7.2	292	53	30 098 13.40	
			50	3 to 7.2	292	53	30 098 13.50	
250	4	28.8	40	3 to 7.2	292	53	30 098 13.40	
			50	3 to 7.2	292	53	30 098 13.50	
315	4	36.3	50	3 to 7.2	292	53	30 098 13.50	
			63	3 to 7.2	292	67	30 099 13.63	
400	4	46.1	63	3 to 7.2	292	67	30 099 13.63	
			80	3 to 7.2	292	67	30 099 13.80	
6.0 to 7.2	20	4	1.9	6.3	6 to 12	292	53	30 004 13.6,3
				6.3	3 to 7.2	292	53	30 098 13.6,3
				6.3	6 to 12	442	53	30 101 13.6,3

Components

Allocation of HV HRC fuses and transformer ratings

Operating voltage kV	Transformer			HV HRC fuse				
	Rated power S_N kVA	Relative impedance voltage u_k %	Rated current I_1 A	Rated normal current of fuse I_{fuse} A	Operating voltage U_{fuse} kV	Dimension e mm	Outside diameter d mm	Order No. Make SJBA
6 to 7.2	50	4	4.8	10	3 to 7.2	292	53	30 098 13.10
				10	6 to 12	292	53	30 004 13.10
				10	6 to 12	442	53	30 101 13.10
				16	3 to 7.2	292	53	30 098 13.16
				16	6 to 12	292	53	30 004 13.16
				16	6 to 12	442	53	30 101 13.16
	75	4	7.2	16	3 to 7.2	292	53	30 098 13.16
				16	6 to 12	292	53	30 004 13.16
				16	6 to 12	442	53	30 101 13.16
	100	4	9.6	16	3 to 7.2	292	53	30 098 13.16
				16	6 to 12	292	53	30 004 13.16
				16	6 to 12	442	53	30 101 13.16
				20	3 to 7.2	292	53	30 098 13.20
				20	6 to 12	292	53	30 004 13.20
				20	6 to 12	442	53	30 101 13.20
	125	4	12	20	3 to 7.2	292	53	30 098 13.20
				20	6 to 12	292	53	30 004 13.20
				20	6 to 12	442	53	30 101 13.20
				25	3 to 7.2	292	53	30 098 13.25
				25	6 to 12	292	53	30 004 13.25
				25	6 to 12	442	53	30 101 13.25
	160	4	15.4	31.5	3 to 7.2	292	53	30 098 13.31,5
				31.5	6 to 12	292	53	30 004 13.31,5
				31.5	6 to 12	442	53	30 101 13.31,5
	200	4	19.2	31.5	3 to 7.2	292	53	30 098 13.31,5
				31.5	6 to 12	292	53	30 004 13.31,5
				31.5	6 to 12	442	53	30 101 13.31,5
				40	3 to 7.2	292	53	30 098 13.40
				40	6 to 12	292	53	30 004 13.40
				40	6 to 12	442	53	30 101 13.40
	250	4	24	40	3 to 7.2	292	53	30 098 13.40
				40	6 to 12	292	53	30 004 13.40
				40	6 to 12	442	53	30 101 13.40
				50	3 to 7.2	292	53	30 098 13.50
				50	6 to 12	292	53	30 004 13.50
				50	6 to 12	442	53	30 101 13.50
				63	6 to 12	292	67	30 012 43.63
				63	6 to 12	442	67	30 102 43.63
	315	4	30.3	50	3 to 7.2	292	53	30 098 13.50
				50	6 to 12	292	53	30 004 13.50
				50	6 to 12	442	53	30 101 13.50
				63	6 to 12	292	67	30 012 43.63
	400	4	38.4	63	6 to 12	292	67	30 012 43.63
				80	6 to 12	292	67	30 012 43.80
				80	6 to 12	442	67	30 102 43.80
				63	3 to 7.2	292	67	30 099 13.63
				63	6 to 12	292	67	30 012 13.63
				63	6 to 12	442	67	30 102 13.63
500	4	48	80	6 to 12	292	67	30 012 43.80	
			80	6 to 12	442	67	30 102 43.80	
			80	3 to 7.2	292	67	30 099 13.80	
			80	6 to 12	292	67	30 012 13.80	
			80	6 to 12	442	67	30 102 13.80	
			100	6 to 12	292	67	30 012 43.100	
630	4	61	100	6 to 12	442	67	30 102 43.100	
			125	6 to 12	442	85	30 103 43.125	
			125	6 to 12	292	85	30 020 43.125	
10 to 12	20	4	1.15	4	6 to 12	292	53	30 004 13.4
				4	6 to 12	292	53	30 004 13.10
	50	4	2.9	10	6 to 12	442	53	30 101 13.10
				10	10 to 17.5	292	53	30 255 13.10
				10	10 to 17.5	442	53	30 231 13.10
				10	10 to 24	442	53	30 006 13.10
				10	6 to 12	292	53	30 004 13.10
				10	6 to 12	442	53	30 101 13.10
	75	4	4.3	10	6 to 12	292	53	30 004 13.10
				10	6 to 12	442	53	30 101 13.10
				10	10 to 17.5	292	53	30 255 13.10
				10	10 to 17.5	442	53	30 231 13.10
				10	10 to 24	442	53	30 006 13.10
				10	6 to 12	292	53	30 004 13.16
	100	4	5.8	16	6 to 12	292	53	30 004 13.16
				16	6 to 12	442	53	30 101 13.16
				16	10 to 17.5	292	53	30 255 13.16
				16	10 to 17.5	442	53	30 231 13.16
16				10 to 24	442	53	30 006 13.16	
16				10 to 24	442	53	30 006 13.16	

Components

Allocation of HV HRC fuses and transformer ratings

Operating voltage kV	Transformer			HV HRC fuse				Order No. Make SJBA
	Rated power S_N kVA	Relative impedance voltage u_k %	Rated current I_1 A	Rated normal current of fuse I_{fuse} A	Operating voltage U_{fuse} kV	Dimension e mm	Outside diameter d mm	
10 to 12	125	4	7.2	16	6 to 12	292	53	30 004 13.16
				16	6 to 12	442	53	30 101 13.16
				16	10 to 17.5	292	53	30 255 13.16
				16	10 to 17.5	442	53	30 231 13.16
				16	10 to 24	442	53	30 006 13.16
	160	4	9.3	20	6 to 12	292	53	30 004 13.20
				20	6 to 12	442	53	30 101 13.20
				20	10 to 17.5	292	67	30 221 13.20
				20	10 to 17.5	442	53	30 231 13.20
				20	10 to 24	442	53	30 006 13.20
	200	4	11.5	25	6 to 12	292	53	30 004 13.25
				25	6 to 12	442	53	30 101 13.25
				25	10 to 17.5	292	67	30 221 13.25
				25	10 to 17.5	442	53	30 231 13.25
				25	10 to 24	442	53	30 006 13.25
	250	4	14.5	25	6 to 12	292	53	30 004 13.25
				25	6 to 12	442	53	30 101 13.25
				25	10 to 17.5	292	67	30 221 13.25
				25	10 to 17.5	442	53	30 231 13.25
				25	10 to 24	442	53	30 006 13.25
				31.5	6 to 12	292	53	30 004 13.31,5
				31.5	6 to 12	442	53	30 101 13.31,5
				31.5	10 to 17.5	292	67	30 221 13.31,5
				31.5	10 to 17.5	442	53	30 231 13.31,5
				31.5	10 to 24	442	53	30 006 13.31,5
				315	4	18.3	31.5	6 to 12
	31.5	6 to 12	442				53	30 101 13.31,5
	31.5	10 to 17.5	292				67	30 221 13.31,5
	31.5	10 to 17.5	442				53	30 231 13.31,5
	31.5	10 to 24	442				53	30 006 13.31,5
	40	6 to 12	292				53	30 004 13.40
	40	6 to 12	442				53	30 101 13.40
	40	10 to 17.5	292				67	30 221 13.40
	40	10 to 17.5	442				53	30 231 13.40
	40	10 to 24	442				53	30 006 13.40
	400	4	23.1				40	6 to 12
				40	6 to 12	442	53	30 101 13.40
				40	10 to 17.5	292	67	30 221 13.40
				40	10 to 17.5	442	53	30 231 13.40
				40	10 to 24	442	53	30 006 13.40
				50	6 to 12	292	53	30 004 13.50
				50	6 to 12	442	53	30 101 13.50
				50	10 to 17.5	292	67	30 221 13.50
				50	10 to 17.5	442	67	30 232 13.50
				50	10 to 24	442	67	30 014 13.50
				500	4	29	50	6 to 12
	50	6 to 12	442				53	30 101 13.50
	50	10 to 17.5	292				67	30 221 13.50
50	10 to 17.5	442	67				30 232 13.50	
50	10 to 24	442	67				30 014 13.50	
63	6 to 12	292	67				30 012 43.63	
630	4	36.4	63	10 to 24	442	67	30 014 43.63	
			80	10 to 24	442	67	30 014 43.80	
			63	6 to 12	292	67	30 012 13.63	
			63	6 to 12	442	67	30 102 13.63	
			63	10 to 17.5	442	67	30 232 13.63	
			80	6 to 12	292	67	30 012 43.80	
800	5 to 6	46.2	80	6 to 12	292	67	30 012 43.80	
			80	6 to 12	442	67	30 102 43.80	
			80	6 to 12	442	67	30 102 43.80	
1000	5 to 6	58	100	6 to 12	442	67	30 102 43.100	
13.8	1250	5 to 6	72.2	125	6 to 12	442	85	30 103 43.125
					10 to 24	442	53	30 006 13.3,15
	50	4	2.1	6.3	10 to 17.5	442	53	30 231 13.6,3
					10 to 24	442	53	30 006 13.6,3
	75	4	3.2	6.3	10 to 17.5	442	53	30 231 13.6,3
					10 to 17.5	442	53	30 231 13.10
					10 to 24	442	53	30 006 13.10
	100	4	4.2	10	10 to 17.5	442	53	30 231 13.10
					10 to 17.5	442	53	30 231 13.16
					10 to 24	442	53	30 006 13.16

Components

Allocation of HV HRC fuses and transformer ratings

Operating voltage kV	Transformer			HV HRC fuse				Order No. Make SIBA	
	Rated power S_N kVA	Relative impedance voltage u_k %	Rated current I_1 A	Rated normal current of fuse I_{fuse} A	Operating voltage U_{fuse} kV	Dimension e mm	Outside diameter d mm		
13.8	125	4	5.3	10	10 to 17.5	442	53	30 231 13.10	
				16	10 to 17.5	442	53	30 231 13.16	
				16	10 to 24	442	53	30 006 13.16	
	160	4	6.7	8.4	16	10 to 17.5	442	53	30 231 13.16
					20	10 to 17.5	442	53	30 231 13.20
					20	10 to 24	442	53	30 006 13.20
	200	4	8.4	10.5	20	10 to 17.5	442	53	30 231 13.20
					25	10 to 17.5	442	53	30 231 13.25
					25	10 to 24	442	53	30 006 13.25
	250	4	10.5	13.2	25	10 to 17.5	442	53	30 231 13.25
					31.5	10 to 17.5	442	53	30 231 13.31,5
					31.5	10 to 24	442	53	30 006 13.31,5
315	4	13.2	16.8	31.5	10 to 17.5	442	53	30 231 13.31,5	
				31.5	10 to 24	442	53	30 006 13.31,5	
				40	10 to 17.5	442	53	30 231 13.40	
400	4	16.8	21	40	10 to 17.5	442	53	30 231 13.40	
				40	10 to 24	442	53	30 006 13.40	
				50	10 to 17.5	442	67	30 232 13.50	
500	4	21	26.4	50	10 to 24	442	67	30 014 13.50	
				63	10 to 24	442	67	30 014 43.63	
				80	10 to 24	442	67	30 014 43.80	
630	4	26.4	33.5	80	10 to 24	442	67	30 014 43.80	
				100	10 to 24	442	67	30 014 43.80	
				100	10 to 24	442	67	30 014 43.80	
15 to 17.5	20	4	0.77	3.15	10 to 24	442	53	30 006 13.3,15	
				6.3	10 to 17.5	442	53	30 231 13.6,3	
				6.3	10 to 24	442	53	30 006 13.6,3	
	50	4	1.9	2.9	6.3	10 to 17.5	442	53	30 231 13.6,3
					10	10 to 17.5	442	53	30 231 13.10
					16	10 to 17.5	442	53	30 231 13.16
	75	4	2.9	3.9	16	10 to 17.5	442	53	30 231 13.16
					16	10 to 24	442	53	30 006 13.16
					20	10 to 17.5	442	53	30 231 13.20
	100	4	3.9	4.8	20	10 to 17.5	442	53	30 231 13.20
					20	10 to 24	442	53	30 006 13.20
					25	10 to 17.5	442	53	30 231 13.25
	125	4	4.8	6.2	25	10 to 24	442	53	30 006 13.25
					31.5	10 to 17.5	442	53	30 231 13.31,5
					31.5	10 to 24	442	53	30 006 13.31,5
	160	4	6.2	7.7	31.5	10 to 17.5	442	53	30 231 13.31,5
					31.5	10 to 24	442	53	30 006 13.31,5
					40	10 to 17.5	442	53	30 231 13.40
	200	4	7.7	9.7	40	10 to 17.5	442	53	30 231 13.40
					40	10 to 24	442	53	30 006 13.40
					50	10 to 17.5	442	67	30 232 13.50
	250	4	9.7	12.2	50	10 to 24	442	67	30 014 13.50
					63	10 to 24	442	67	30 014 43.63
					80	10 to 24	442	67	30 014 43.63
315	4	12.2	15.5	80	10 to 24	442	67	30 014 43.63	
				100	10 to 24	442	67	30 014 43.80	
				100	10 to 24	442	67	30 014 43.80	
400	4	15.5	19.3	100	10 to 24	442	85	30 022 43.100	
				31.5	10 to 17.5	442	53	30 231 13.31,5	
				31.5	10 to 24	442	53	30 006 13.31,5	
500	4	19.3	24.3	40	10 to 17.5	442	53	30 231 13.40	
				40	10 to 24	442	53	30 006 13.40	
				50	10 to 17.5	442	67	30 232 13.50	
630	4	24.3	30.9	50	10 to 24	442	67	30 014 13.50	
				63	10 to 24	442	67	30 014 43.63	
				80	10 to 24	442	67	30 014 43.63	
20 to 24	800	5 to 6	30.9	80	10 to 24	442	67	30 014 43.80	
				100	10 to 24	442	67	30 014 43.80	
				100	10 to 24	442	67	30 014 43.80	
	1000	5 to 6	38.5	48.2	100	10 to 24	442	67	30 014 43.80
					1250	10 to 24	442	67	30 014 43.80
					1250	10 to 24	442	67	30 014 43.80
	1250	5 to 6	48.2	0.57	3.15	10 to 24	442	53	30 006 13.3,15
					6.3	10 to 24	442	53	30 006 13.6,3
					6.3	10 to 24	442	53	30 006 13.6,3
	1600	5 to 6	46.5	1.5	6.3	10 to 24	442	53	30 006 13.6,3
					10	10 to 24	442	53	30 006 13.10
					10	10 to 24	442	53	30 006 13.10
	2000	5 to 6	57.8	2.2	6.3	10 to 24	442	53	30 006 13.6,3
					10	10 to 24	442	53	30 006 13.10
					10	10 to 24	442	53	30 006 13.10
	2500	5 to 6	57.8	2.9	6.3	10 to 24	442	53	30 006 13.6,3
					10	10 to 24	442	53	30 006 13.10
					10	10 to 24	442	53	30 006 13.10
	3150	5 to 6	57.8	3.6	10	10 to 24	442	53	30 006 13.10
					10	10 to 24	442	53	30 006 13.10
					10	10 to 24	442	53	30 006 13.10
	4000	5 to 6	57.8	4.7	10	10 to 24	442	53	30 006 13.10
					16	10 to 24	442	53	30 006 13.16
					16	10 to 24	442	53	30 006 13.16
5000	5 to 6	57.8	5.8	16	10 to 24	442	53	30 006 13.16	
				20	10 to 24	442	53	30 006 13.20	
				20	10 to 24	442	53	30 006 13.20	
6300	5 to 6	57.8	7.3	16	10 to 24	442	53	30 006 13.16	
				25	10 to 24	442	53	30 006 13.25	
				25	10 to 24	442	53	30 006 13.25	
8000	5 to 6	57.8	9.2	25	10 to 24	442	53	30 006 13.25	
				31.5	10 to 24	442	53	30 006 13.31,5	
				31.5	10 to 24	442	53	30 006 13.31,5	
10000	5 to 6	57.8	11.6	31.5	10 to 24	442	53	30 006 13.31,5	
				40	10 to 24	442	53	30 006 13.40	
				40	10 to 24	442	53	30 006 13.40	
12500	5 to 6	57.8	14.5	40	10 to 24	442	53	30 006 13.40	
				50	10 to 24	442	67	30 014 13.50	
				50	10 to 24	442	67	30 014 13.50	
16000	5 to 6	57.8	18.2	50	10 to 24	442	67	30 014 13.50	
				63	10 to 24	442	67	30 014 43.63	
				80	10 to 24	442	67	30 014 43.80	
20000	5 to 6	57.8	23.1	80	10 to 24	442	67	30 014 43.80	
				100	10 to 24	442	67	30 014 43.80	
				100	10 to 24	442	67	30 014 43.80	
25000	5 to 6	57.8	29	100	10 to 24	442	67	30 014 43.80	
				1250	10 to 24	442	67	30 014 43.80	
				1250	10 to 24	442	67	30 014 43.80	
31500	5 to 6	57.8	36	1250	10 to 24	442	67	30 014 43.80	
				1600	10 to 24	442	85	30 022 43.100	
				1600	10 to 24	442	85	30 022 43.100	
40000	5 to 6	57.8	46.5	1600	10 to 24	442	85	30 022 43.100	
				2000	10 to 24	442	85	30 022 43.100	
				2000	10 to 24	442	85	30 022 43.100	
50000	5 to 6	57.8	57.8	2000	10 to 24	442	85	30 022 43.100	
				2000	10 to 24	442	85	30 022 43.100	
				2000	10 to 24	442	85	30 022 43.100	

Components

Cable-type current transformers 4MC70 33 and 4MC70 31

Features

- According to IEC / EN 60044-1 / VDE 0414-1
- Designed as ring-core current transformers, 1-pole
- Free of dielectrically stressed cast-resin parts (due to design)
- Insulation class E
- Inductive type
- Secondary connection by means of a terminal strip in the panel.

Installation

The mounting location is outside the switchgear vessel, around the cable at the panel connection; factory-assembled on transformer mounting plate, installation on the cable on site.

Note: Installation inside or underneath the panel depending on the panel type and the overall transformer height.

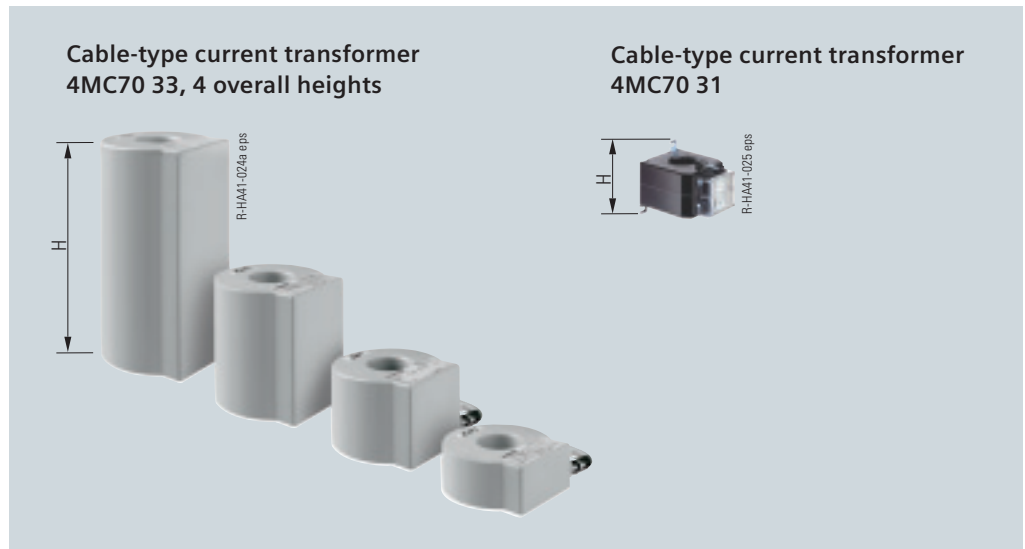

Technical data

Cable-type current transformer 4MC70 33

Primary data

Highest voltage for equipment U_m	0.72 kV
Rated current I_N	20 A to 600 A
Rated short-duration power-frequency withstand voltage (winding test)	3 kV
Rated short-time thermal current I_{th}	up to 25 kA / 1 s or 20 kA / 3 s
Rated continuous thermal current I_D	$1.2 \times I_N$
Transient overload current	$1.5 \times I_D / 1 \text{ h}$ or $2 \times I_D / 0.5 \text{ h}$
Rated dynamic current I_{dyn}	$2.5 \times I_{th}$

Secondary data

Rated current	1 A or 5 A, optionally: multiratio	
Measuring core	Class	0.2 0.5 1
	Overcurrent factor	without FS5 FS10
	Rating	2.5 VA to 30 VA
Protection core	Class	10 P 5 P
	Overcurrent factor	10 20 30
	Rating	1 VA to 30 VA

Dimensions

Overall height H , depending on core data	mm	65	110	170	285
Outside diameter		150 mm			
Inside diameter		55 mm			
For cable diameter		50 mm			

Other values on request

Cable-type current transformer 4MC70 31

Primary data

Highest voltage for equipment U_m	0.72 kV
Rated current I_N	50 A to 600 A
Rated short-duration power-frequency withstand voltage (winding test)	3 kV
Rated short-time thermal current I_{th}	up to 25 kA / 1 s or 14.5 kA / 3 s
Rated continuous thermal current I_D	$1.2 \times I_N$
Transient overload current	$1.5 \times I_D / 1 \text{ h}$ or $2 \times I_D / 0.5 \text{ h}$
Rated dynamic current I_{dyn}	$2.5 \times I_{th}$

Secondary data

Rated current	1 A or 5 A	
Measuring core	Class	1
	Overcurrent factor	FS5
	Rating	2.5 VA to 10 VA

Dimensions

Overall height H	89 mm
Width x Depth	85 mm x 114 mm
Inside diameter	40 mm
For cable diameter	36 mm

Other values on request

Features

- According to IEC/EN 60044-1 / VDE 0414-1
- Designed as ring-core current transformer, 3-pole
- Free of dielectrically stressed cast-resin parts (due to design)
- Insulation class E
- Inductive type
- Climate-independent
- Secondary connection by means of a terminal strip in the panel.

Installation

- Mounting location:
 - For individual panels type R500 and L500 (optional)
 - Arranged outside the switchgear vessel on the bushings of the cable connection
 - Factory-assembled.

Further designs (option)

For protection equipment based on the current-transformer operation principle:

- Protection system 7SJ45 as definite-time overcurrent protection
- Definite-time overcurrent protection relay, make Woodward/SEG, type WIP 1
- Definite-time overcurrent protection relay, make Woodward/SEG, type WIC.

Three-phase current transformer 4MC63



Technical data

Three-phase current transformer 4MC63 10 for $I_N \leq 150$ A and $I_D = 630$ A

Primary data

Highest voltage for equipment U_m	0.72 kV				
Rated current I_N	A	150	100	75	50
Rated short-duration power-frequency withstand voltage (winding test)	3 kV				
Rated short-time thermal current I_{th}	up to 25 kA / 1 s or 20 kA / 3 s				
Rated continuous thermal current I_D	630 A				
Transient overload current	$1.5 \times I_D / 1$ h				
Rated dynamic current I_{dyn}	$2.5 \times I_{th}$				

Secondary data

Rated current	A	1	0.67	0.5	0.33
Rating	VA	2.5	1.7	1.25	0.8
Current at I_D	4.2 A				
Protection core	Class	10 P			
	Overcurrent factor	10			

Other values on request

Three-phase current transformer 4MC63 11 for $I_N \leq 400$ A and $I_D = 630$ A

Primary data

Highest voltage for equipment U_m	0.72 kV			
Rated current I_N	A	400	300	200
Rated short-duration power-frequency withstand voltage (winding test)	3 kV			
Rated short-time thermal current I_{th}	up to 25 kA / 1 s or 20 kA / 3 s			
Rated continuous thermal current I_D	630 A			
Transient overload current	$2 \times I_D / 0.5$ h			
Rated dynamic current I_{dyn}	$2.5 \times I_{th}$			

Secondary data

Rated current	A	1	0.75	0.5
Rating	VA	4	3	2
Current at I_D	1.575 A			
Protection core	Class	10 P		
	Overcurrent factor	10		

Other values on request

Components

Bus-type current transformer 4MC70 32

Features

- According to IEC/EN 60044-1 / VDE 0414-1
- Designed as ring-core current transformers, 1-pole
- Free of dielectrically stressed cast-resin parts (due to design)
- Insulation class E
- Inductive type
- Secondary connection by means of a terminal strip in the panel.

Installation

- Mounting location:
 - Arranged outside the switchgear vessel on the screened busbar section in bus sectionalizer panels type S and V with the option of busbar current transformers.
 - Arranged outside the switchgear vessel around the cable at the panel connection for 310 mm panel width (cable feeders type R and K), transformers mounted on a supporting plate at the factory; final assembly around the cables on site.

Note: Depending on the transformer overall height: Installation in or underneath the panel.

Bus-type current transformer 4MC70 32

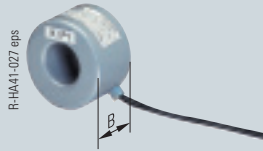

Technical data

Bus-type current transformer 4MC70 32

Primary data

Highest voltage for equipment U_m	0.72 kV
Rated current I_N	200 A to 600 A
Rated short-duration power-frequency withstand voltage (winding test)	3 kV
Rated short-time thermal current I_{th}	up to 25 kA/1 s or 20 kA/3 s
Rated continuous thermal current I_D	$1.2 \times I_N$
Transient overload current	$1.5 \times I_D/1 \text{ h}$ or $2 \times I_D/0.5 \text{ h}$
Rated dynamic current I_{dyn}	$2.5 \times I_{th}$

Secondary data

Rated current	1 A (option: 5 A)		
Measuring core	Class	0.2	0.5 1
	Overcurrent factor	without	FS5 FS10
	Rating	2.5 VA to 10 VA	
Protection core	Class	10 P	5 P *)
	Overcurrent factor	10	10
	Rating	2.5 VA to 15 VA	

Dimensions

Overall width B, depending on core data	80 mm / 150 mm
Outside diameter	125 mm
Inside diameter	55 mm

Other values on request *) On request

Panel section type V

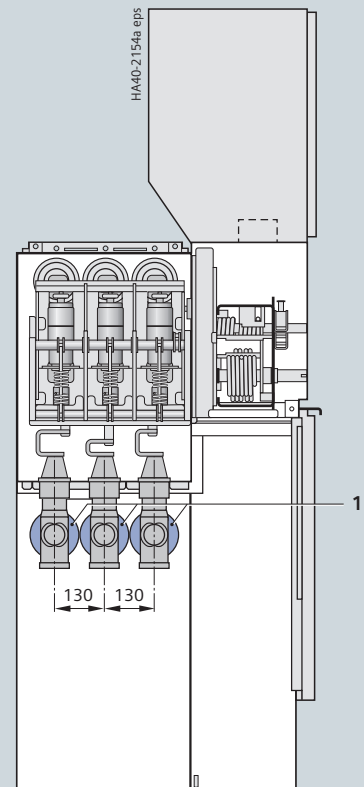

1 Bus-type current transformer 4MC70 32

Components

Plug-in voltage transformers 4MT3 and 4MT8

Common features

- According to IEC/EN 60044-2 / VDE 0414-2
- 1-pole, plug-in design
- Inductive type
- Connection with plug-in contact
- Safe-to-touch due to metal cover
- Secondary connection by means of plugs inside the panel.

Features of type 4MT3

- Metal-coated or metal-enclosed (option)
- For outside-cone system type A.

Installation

- Mounting location:
 - Arranged above the switchgear vessel in individual panels type L500, V and E (optional)
 - Arranged in front of the switchgear vessel in individual panel type M500
 - Direct connection to the busbar.

Features of type 4MT8

- Metal-enclosed
- For connection to the cable plug-in unit (screened).

Installation

- Mounting location:
 - Arranged in the cable compartment of individual panels type L500 and R500 (optional).

Plug-in voltage transformer 4MT3 (at the busbar)

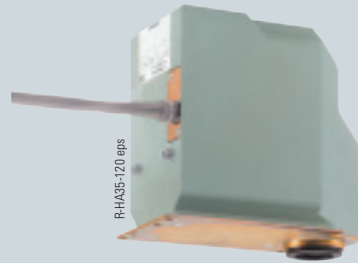

Plug-in voltage transformer 4MT8 (at the cable connection)



Technical data

for types 4MT3 *) and 4MT8 *)

Primary data

Highest voltage for equipment $1.2 \times U_n$	
Rated voltage (8 h) $= 1.9 \times U_n$	
Rated voltage U_r	Operating voltage U_n
kV	$kV / \sqrt{3}$
3.6	3.3
7.2	3.6
	4.2
	4.8
	5.0
	6.0
	6.3
	6.6
12	7.2
	10.0
	11.0
	11.6
	17.5
17.5	12.8
	13.2
	13.8
	15.0
	16.0
	24
20.0	
22.0	
23.0	

Secondary data

Rated voltage	1 st winding	$100 / \sqrt{3}$
		$110 / \sqrt{3}$
	Auxiliary winding (option)	100 / 3
		110 / 3

for 4MT3

Rated long-time current (8 h)	6 A	Class
Rating in VA up to	20	0.2
	60	0.5
	120	1.0

for 4MT8

Rated long-time current (8 h)	6 A	Class
Rating in VA up to	25	0.2
	75	0.5
	120	1.0

Combination of voltage transformers 4MT8 *) with cable T-plugs (screened, without metal housing)

Make	Type	Combination	Make	Type	Combination
Euromold	(K) 400 TB/G	Yes	Südkabel	SEHDT (13/23)	Yes
	(K) 440 TB, AGT 10/20		Südkabel	SET (12/24)	On request
nkt cables	ASTS 10/630, ASTS 20/630	Yes	Cooper	DT 400 P	Yes
	Prysmian Kabel und Systeme		FMCTs-400, FMCTg-400	Yes	

*) Removal required for dielectric test of switchgear on site (max. 80 % U_d)

Components

Current transformers 4MA7 and voltage transformers 4MR for air-insulated billing metering panels

Features

Current transformer 4MA7

- According to IEC/EN 60044-1 / VDE 0414-1
- Dimensions according to DIN 42600-8 (small design)
- Designed as indoor block-type current transformer, 1-pole
- Cast-resin insulated
- Insulation class E
- Secondary connection by means of screw-type terminals.

Voltage transformer 4MR

- According to IEC/EN 60044-2 / VDE 0414-2
- Dimensions according to DIN 42600-9 (small design)
- Designed as indoor voltage transformer:
 - Type 4MR, 1-pole
 - Option: Type 4MR, 2-pole
- Cast-resin insulated
- Insulation class E
- Secondary connection by means of screw-type terminals.

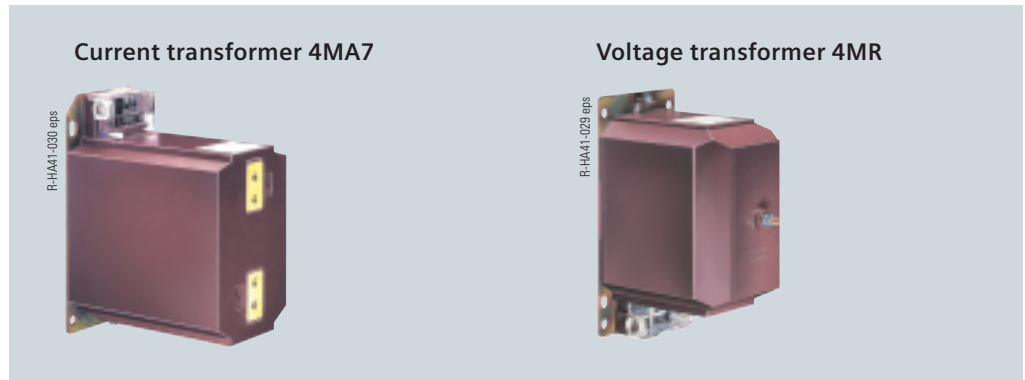

Technical data

Current transformer 4MA7, 1-pole

Primary data

Highest voltage for equipment U_m	up to 24 kV
Rated short-duration power-frequency withstand voltage U_d	up to 50 kV
Rated lightning impulse withstand voltage U_p	up to 125 kV
Rated current I_N	20 A to 600 A
Rated short-time thermal current I_{th}	up to 25 kA / 1 s
Rated continuous thermal current I_D	$1.2 \times I_N$
Rated dynamic current I_{dyn}	max. $2.5 \times I_{th}$

Secondary data

Rated current	1 A or 5 A	
Measuring core	Class	0.2 0.5 1
	Overcurrent factor	without FS5 FS10
	Rating	2.5 VA to 30 VA
Protection core	Class	5 P or 10 P
	Overcurrent factor	10
	Rating	2.5 VA to 30 VA

Other values on request

Voltage transformer 4MR, 1-pole

Primary data

Highest voltage for equipment $1.2 \times U_n$	
Rated voltage (8 h) = $1.9 \times U_n$	
Rated voltage U_r	Operating voltage U_n
kV	$kV / \sqrt{3}$
3.6	3.3
7.2	3.6
	4.2
	4.8
	5.0
12	6.0
	6.3
	6.6
	7.2
17.5	10.0
	11.0
	11.6
	12.8
24	13.2
	13.8
	15.0
	16.0
	17.5
	20.0
	22.0
23.0	

Secondary data

Rated voltage	1 st winding	$100 / \sqrt{3}$
		$110 / \sqrt{3}$
		$120 / \sqrt{3}$
	Auxiliary winding (option)	100 / 3
		110 / 3
		120 / 3
Rating in VA up to		Class
	20	0.2
	50	0.5
	100	1.0

Other values on request

Features

- Access to the cable compartment only if the feeder has been disconnected and earthed
- Bushings according to DIN EN 50181 with outside cone and bolted connection M16 as interface type "C".

Connection of

- Cable elbow plugs or cable T-plugs with bolted contact M16 for 630 A
- Paper-insulated mass-impregnated cables via customary adapters
- Thermoplastic-insulated single-core cables with the corresponding plugs and adapters mentioned above.

Option

- Mounted cable clamps on cable bracket.

Cable sealing ends

- As screened (semi-conductive) design independent of the site altitude, or as unscreened (insulated) design, but then dependent on the site altitude.

Surge arresters

- Pluggable on cable T-plug, cable elbow plug or T-adapter
- The switchgear depth can be extended when surge arresters are mounted (depending on the make and type)
- Surge arresters recommended if, at the same time,
 - the cable system is directly connected to the overhead line,
 - the protection zone of the surge arrester at the end tower of the overhead line does not cover the switchgear.

Surge limiters

- Pluggable on cable T-plug
- Surge limiters recommended when motors with starting currents < 600 A are connected.

Cable compartment

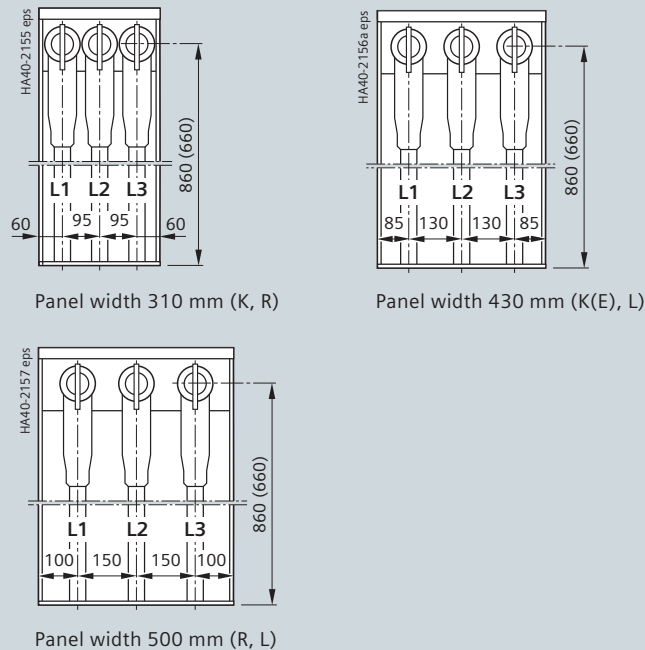

Connection options

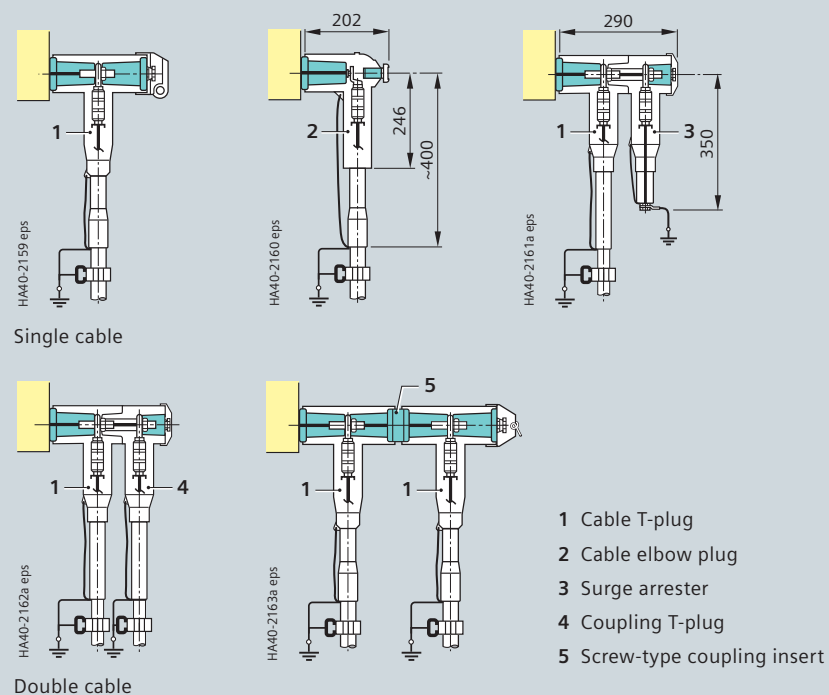

Note:

Cable plugs, cable sealing ends and cable clamps are not included in the scope of supply.

Components

Cable sealing ends (further types on request)

Cable type	Cable sealing end						Type
	Make	Serial no.	Type	Design T / W ¹⁾	Conductor cross-sec. mm ²	Insulation	

Thermoplastic-insulated cables ≤ 12 kV according to IEC/EN 60502-2 / VDE 0276-620

1-core or 3-core cable, PE and XLPE-insulated N2YSY (Cu) and N2XSY (Cu) or NA2YSY (Al) and NA2XSY (Al)	Euromold	1	400 TB / G, 430 TB-630	T	35–300	EPDM	Screened
		2	400 LB / G	W	35–300	EPDM	Screened
		3	440 TB / G	T	185–630	EPDM	Screened
	nkt cables	4	CB 24-630 (ASTS 10 / 630)	T	25–300	Silicone	Screened, option: with metal housing
		5	AB 24-630	T	25–300	Silicone	Insulated
		6	On request: CB 36-630	T	400–630	Silicone	For 12, 24, 36 kV
	Südkabel	7	SET 12	T	50–300	Silicone	Screened, option: with metal housing
		8	SEHDT 13	T	50–300	Silicone	Screened, option: with metal housing
		9	SEHDK 13.1	T	70–300	Silicone	Screened, for double cable w. SET and SEHDT
	Pfisterer	10	CAT 20 / 630	T	95–240	Silicone	Screened
	Cooper Power Systems ²⁾	11	DT 400 P	T	50–400	EPDM	Screened
	Prysmian Kabel und Systeme (Pirelli Elektrik)	12	FMCTs-400	T	25–300	EPDM	Screened
		13	FMCTsm-400	T	25–300	EPDM	Screened, with metal housing
		14	FMCTj-400	T	25–300	EPDM	Screened, suitable for cable sheath test
	3M Deutschland	15	93-EE 705-6 / -95	T	50–95	Silicone	Screened, option: with metal housing
		16	93-EE 705-6 / -240	T	95–240	Silicone	Screened, option: with metal housing
	Tyco Electronics Raychem	17	RICS 51... with IXSU	T	25–300	Silicone	T-adapter with sealing end (Elastomer)
		18	RSTH-L56xx, -58xx	T	25–300	Silicone	Screened, with capacitive measuring point

Thermoplastic-insulated cables 15 / 17.5 / 24 kV according to IEC/EN 60502-2 / VDE 0276-620

1-core or 3-core cable, PE and XLPE-insulated N2YSY (Cu) and N2XSY (Cu) or NA2YSY (Al) and NA2XSY (Al)	Euromold	19	K400 TB / G, 430 TB-630	T	35–300	EPDM	Screened
		20	K400 LBG	W	35–300	EPDM	Screened
		21	K440 TB / G	T	185–630	EPDM	Screened
	nkt cables	22	CB 24-630	T	25–300	Silicone	Screened, option: with metal housing
		23	AB 24-630	T	25–300	Silicone	Insulated
	Südkabel	24	SET 24	T	25–240	Silicone	Screened, option: with metal housing
		25	SEHDT 23	T	35–300	Silicone	Screened, option: with metal housing
		26	SEHDK 23.1	T	35–240	Silicone	Screened, for double cable w. SET and SEHDT
	Pfisterer	27	CAT 20 / 630	T	95–240	Silicone	Screened
	Cooper Power Systems ²⁾	28	DT 400 P	T	35–400	EPDM	Screened
	Prysmian Kabel und Systeme (Pirelli Elektrik)	29	FMCTs-400	T	25–240	EPDM	Screened
		30	FMCTsm-400	T	25–240	EPDM	Screened, with metal housing
		31	FMCTj-400	T	25–300	EPDM	Screened, suitable for cable sheath test
	3M Deutschland	32	93-EE 705-6 / -95	T	25–95	Silicone	Screened, option: with metal housing
		33	93-EE 705-6 / -240	T	95–240	Silicone	Screened, option: with metal housing
	Tyco for Electronics Raychem 1-core cables for 3-core cables	34	RICS 51.. with IXSU	T	25–300	Silicone	T-adapter with sealing end
		35	RSTI L58xx	T	25–300	Silicone	Screened, with capacitive measuring point
36		RICS 51.. with IXSU	T	25–300	Silicone	T-adapter with sealing end	
37		RSTH-L58xx	T	25–300	Silicone	Screened, with capacitive measuring point	

Paper-insulated mass-impregnated cables ≤ 12 kV according to IEC/EN 60055-2 / VDE 0276-621

3-core cable as a belted cable, paper-insulated N(A)KBA: 6 / 10 kV	Tyco Electronics Raychem	38	RICS 51.. with UHGK/EPKT	T	95–300	Silicone	T-adapter with sealing end
1-core or 3-core cable as a sheathed cable, paper-insulat. N(A)EKEBA: 6 / 10 kV	Tyco Electronics Raychem	40	RICS 51.. with IDST 51..	T	50–300	Silicone	T-adapter with sealing end

Paper-insulated mass-impregnated cables 15 / 17.5 / 24 kV according to IEC/EN 60055-2 / VDE 0276-621

1-core or 3-core cable, paper-insulated N(A)KLEY, N(A)KY or N(A)EKBA: 12 / 20 kV	Tyco Electronics Raychem	41	RICS 51.. with IDST 51..	T	35–240	Silicone	T-adapter with sealing end
---	--------------------------	----	--------------------------	---	--------	----------	----------------------------

1) T = Cable T-plug, W = Cable elbow plug

2) IEC/EN 60071, VDE 0278, BS 7215, ANSI / IEEE 386, CENELEC HD 629.1 S1

Cable connections for double and single cables with surge arresters

To increase the mounting depth in the cable compartment, deep cable compartment covers can be ordered optionally. The assignment to selected types of cable plugs and cable plug / surge arrester combinations is given in the following tables.

Types of deep cable compartment covers

Type of deep cable compartment cover	Deeper by a (mm)	Cable routing in extended base frame for double cable connection or Ü + K
H315 o.r.	25	No
H340 o.r.	50	No
H395	105	Yes
H435	150	Yes
H585	300	Yes

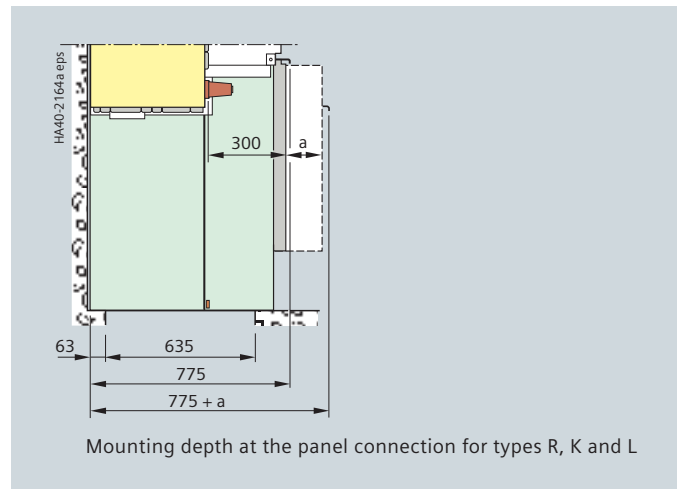

Double cable connection

For individual panels of 500 mm, no deep cable compartment cover and floor opening are required – exception serial no. 2 and no. 6 (on request).

Double cable plugs			Connection combination			Deep cable compartment cover		
Make	Serial no.	Cable plug (type)	Type	Arrangement	Mounting depth (mm)	Type	Deeper by a (mm)	Depth of floor opening (mm)
Euromold	1	430 TB + 300 PB-630A	Screened	K + K	290	–	–	635
	2	2x (K)400 TB/G with coupling insert (K) 400 CP	Screened	K + K	505	H585	300	900
	3	2x (K)400 TB/G with coupling insert (K)400 CP-LB	Screened	K + K	447	H585	300	900
	4	(K)400 TB/G + 430 TB with coupling insert (K)400 CP	Screened	K + K	403	H585	300	900
Südkabel	5	SET (12/24) + SEHDK (13/23)	Screened	K + K	298	–	–	635
	6	SEHDT (13/23) + SET (13/23) with coupling unit KU 23	Screened	K + K	540	H585	300	900
	7	SEHDT (13/23) + SET (12/24) with coupling unit KU 23	Screened	K + K	450	H585	300	900
	8	2x SET (12/24) with coupling unit KU 23.2	Screened	K + K	378	H395	105	715
nkt cables	9	CB 24-630 + CC 24-630	Screened	K + K	290	–	–	635
	10	2x CB 24-630 with coupling unit CP 630C	Screened	K + K	370	H585 H395 o.r.	300 105	900 715
	11	2x AB 24-630 with coupling unit CP 630A	Insulated	K + K	370	H585 H395 o.r.	300 105	900 715
	12	AB 24-630 + AC 24-630	Insulated	K + K	290	H395 o.r.	105	715
Tyco Electronics Raychem	13	RSTI-58xx + RSTI-CC-58xx	Screened	K + K	290	–	–	635

o.r. = on request

K = Cable plug

Ü = Surge arrester

Components

Cable connections for double and single cables with surge arresters

Single cable with surge arrester

For individual panels of 500 mm, no deep cable compartment cover and floor opening are required – exception serial no. 4 and no. 6 (on request).

Cable plug + surge arrester			Connection combination			Deep cable compartment cover	
Make	Serial no.	Cable plug / surge arrester (type)	Type	Arrangement	Mounting depth (mm)	Type	Deeper by a ¹⁾ (mm)
Euromold	1	430 TB + 300 SA-5, -10	Screened	K + Ü	290	–	–
	2	(K)400TB/G + 400 PB-...SA	Screened	K + Ü	410	H435	150
Südkabel	3	SET (12/24) + MUT (13/23)	Screened	K + Ü	301	H395	105
	4	2x SET (12/24) + MUT (13/23) with coupling unit KU 23.2	Screened	K + K + Ü	491	H585	300
	5	SEHDT (13/23) + MUW (12/22) each with metal housing	Screened	K + Ü	435	H435	150
	6	SEHDT (13/23) + MUT 33 each with metal housing	Screened	K + Ü	516	H585	300
nkt cables	7	CB 24-630 + CSA 24-5	Screened	K + Ü	290	–	–
	8	AB 24-630 + ASA 24-5	Insulated	K + Ü	285	H395	105
Tyco Electronics	9	RICS 5139 + RDA...	Insulated	K + Ü	275	–	–
Raychem	10	RSTI-L58xx + RSTI-CC-L58SAxx	Screened	K + Ü	290	–	–

1) See drawing on page 41

K = Cable plug

Ü = Surge arrester

Features

- Access to the cable compartment only if the feeder has been disconnected and earthed
- Bushings according to DIN EN 50181 with outside cone and plug-in contact as interface type "A".

Connection of

- Cable elbow plugs or straight cable plugs
- Connection cross-sections up to 120 mm².

Option

- Mounted cable clamps on cable bracket
- Bushings according to DIN EN 50181 with outside cone and bolted contact as interface type "C" for cable routing downwards.

Routing of transformer cables

when the bushing is arranged

- At the front with cable elbow plug: Downwards (standard)
- At the bottom with cable elbow plug: To the rear (option)
- At the bottom with straight cable plug: Downwards (option).

Cable sealing ends

- As screened (semi-conductive) design independent of the site altitude,
or
as unscreened (insulated) design, but then dependent on the site altitude.

Surge arresters

- Pluggable on cable T-plug, cable elbow plug or T-adaptor.

Cable compartment

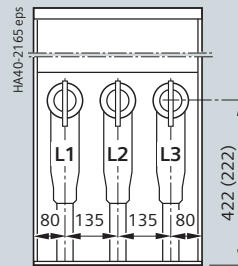

Panel width 430 mm (T)

Connection options

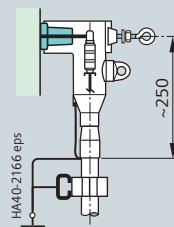

Cable elbow plug
(example)

Cable routing downwards

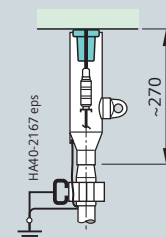

Straight cable plug
(example)

Cable routing downwards

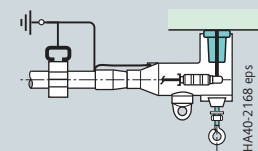

Cable routing to the rear

Note:

Cable plugs, cable sealing ends and cable clamps are not included in the scope of supply.

Components

Cable sealing ends for transformer feeders (further types on request)

Cable type	Cable sealing end						Type
	Make	Serial no.	Type	Design G / W ¹⁾	Conductor cross-sec. mm ²	Insulation	

Thermoplastic-insulated cables ≤ 12 kV according to IEC/EN 60502-2 / VDE 0276-620

1-core or 3-core cable, PE and XLPE-insulated N2YSY (Cu) and N2XSY (Cu) or NA2YSY (Al) and NA2XSY (Al)	Euromold	1	158 LR	W	16–120	EPDM	Screened
		2	151 SR	G	16–70	EPDM	Screened, without capacitive measuring point
		3	152 SR	G	95–120	EPDM	Screened, with capacitive measuring point
		4	AGW 10/250	W	25–95	Silicone	Standard: with metal housing
		5	AGWL 10/250 *)	W	25–95	Silicone	Screened
		6	AGG 10/250	G	25–95	Silicone	Standard: screened, with metal housing
		7	AGGL 10/250 *)	G	25–95	Silicone	Screened
	nkt cables	8	EASW 20/250, size 2	W	25–95	Silicone	Screened, option: with metal housing
		9	EASW 20/250, size 2	W	25–95	Silicone	Screened, option: with metal housing
		10	EASG 20/250, size 2	G	25–95	Silicone	Screened, option: with metal housing
		11	CE 24 – 250	W	95–120	Silicone	Screened
	Südkabel	12	SEHDG 11.1	G	25–120	Silicone	Screened, option: with metal housing
		13	SEW 12	W	25–120	Silicone	Screened, option: with metal housing
	Pfisterer	14	CAW 20/250	W	25–70	Silicone	Screened
	Cooper Power Systems ²⁾	15	DE 250 – R-C	W	16–120	EPDM	Screened
		16	DS 250 – R-C	G	16–120	EPDM	Screened
	Prysmian Kabel und Systeme (Pirelli Elektrik)	17	FMCE-250	W	25–120	EPDM	Screened
		18	FMCEm-250	W	25–120	EPDM	With metal housing
	3M Deutschland	19	93-EE 605-2/-95	W	25–95	Silicone	Screened, option: with metal housing
		20	93-EE 600-2/XX	G	25–150	Silicone	Screened, option: with metal housing
	Tyco Electronics Raychem	21	RSSS 52xx	G	25–95	EPDM	Screened, with capacitive measuring point
		22	RSES 52xx-R	W	25–120	EPDM	Screened and with roll-on sleeve as humidity-proof termination

Thermoplastic-insulated cables 15/17.5/24 kV according to IEC/EN 60502-2 / VDE 0276-620

1-core cable, PE and XLPE-insulated N2YSY (Cu) and N2XSY (Cu) or NA2YSY (Al) and NA2XSY (Al)	Euromold	23	K158 LR	W	16–120	EPDM	Screened, with capacitive measuring point
		24	K152 SR	G	25–120	EPDM	Screened, with capacitive measuring point
		25	AGW 20/250	W	25–95	Silicone	With metal housing
		26	AGWL 20/250	W	25–95	Silicone	Without metal housing
		27	AGG 20/250	G	25–95	Silicone	With metal housing
		28	AGGL 20/250	G	25–95	Silicone	Screened
		nkt cables	29	EASW 20/250, size 3	W	35–120	Silicone
	30		EASG 20/250	G	35–95	Silicone	Screened, option: with metal housing
	31		CE 24 – 250	W	25–95	Silicone	Screened
	Südkabel	32	SEHDG 21.1	G	25–70	Silicone	Screened, option: with metal housing
		33	SEW 24	W	25–95	Silicone	Screened, option: with metal housing
	Pfisterer	34	CAW 20/250	W	25–70	Silicone	Screened
	Cooper Power Systems ²⁾	35	DE 250 – R-C	W	16–120	EPDM	Screened
		36	DS 250 – R-C	G	16–120	EPDM	Screened
	Prysmian Kabel und Systeme (Pirelli Elektrik)	37	FMCE-250	W	25–120	EPDM	Screened
		38	FMCEm-250	W	25–120	EPDM	With metal housing
	3M Deutschland	39	93-EE 605-2/-95	W	25–95	Silicone	Screened, option: with metal housing
		40	93-EE 600-2/XX	G	25–150	Silicone	Screened, option: with metal housing
	Tyco Electronics Raychem	41	RSSS 52xx	G	16–95	EPDM	Screened, with capacitive measuring point
		42	RSES 52xx-R	W	16–120	EPDM	Screened, with capacitive measuring point, with bimetal cable lug

1) G = Straight cable plug W = Cable elbow plug

2) IEC/EN 60071, VDE 0278, BS 7215, ANSI/IEEE 386, CENELEC HD 629.1 S1

*) On request: Without metal housing

Components

Cable connections

Cable testing

- For circuit-breaker and switch-disconnector feeders
- Cable testing equipment can be connected after removing the protective cap and/or the end stopper from the cable plug
- Cable testing equipment and cable T-plug each of the same make
- DC voltage test

Before the test:

Remove any voltage transformers available at the cable connection.

8DJH switchgear for rated voltages up to 24 kV can be subjected to cable tests at a DC test voltage of **max. 96 kV** (when the switchgear is new) or, according to VDE, at 70 kV for 15 minutes. The voltage at the busbar may be 24 kV in this case.

- Test voltages:

Rated voltage		Max. test voltage applied to the connected cable		
		VLF ¹⁾ 0.1 Hz	according to IEC / EN	VDE 0278
U_r (kV)	$U_0/U (U_m)$ (kV)	$3 \cdot U_0$ U_{LF} AC (kV)	U_m DC (kV)	$6 \cdot U_0$, 15 min max. U_m DC (kV)
12	6 / 10(12)	19	24	38 ²⁾
24	12 / 20(24)	38	48	70

- For cable testing, the following must be observed:
 - Installation and operating instructions of the switchgear
 - Standards IEC / EN 62271-200 / VDE 0671-200 *)
 - Data of the manufacturer-specific cable sealing end
 - Cable design (paper-insulated mass-impregnated cable, PVC or XLPE cable).

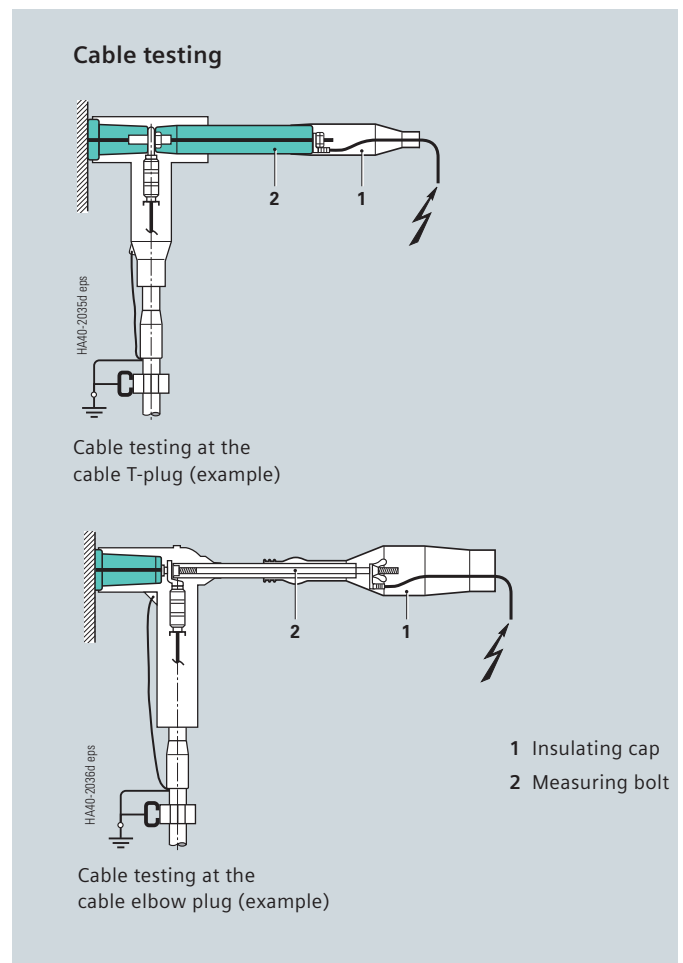

1) VLF = very low frequency

2) Referred to $U_0/U(U_m) = 6.35/11(12 \text{ kV})$

*) For standards, see page 73

Components

Interlocks, locking devices

Standard interlocks

- Three-position switch: Disconnecting function against earthing function
- Circuit-breaker feeder: Circuit-breaker against three-position disconnecter
- Access to cable compartment is generally only possible if
 - the feeder is isolated
 - and
 - the feeder is earthed ("EARTHED" position).

For ring-main and circuit-breaker feeders

- Option: Closing lockout
Prevents switching the three-position switch-disconnector from "OPEN" position to "CLOSED" position when the cable compartment cover is removed.

For transformer feeders

- The three-position switch-disconnector cannot be switched from "EARTHED" to "OPEN" position when the cable compartment cover / the HV HRC fuse compartment is open.

Locking device

- For padlock, hook diameter 12 mm
- Standard for transformer and circuit-breaker feeders (stored-energy mechanisms)
- Option for ring-main feeders (spring-operated mechanisms)
- Three-position switch-disconnector lockable at the operating mechanism in any desired switch position.

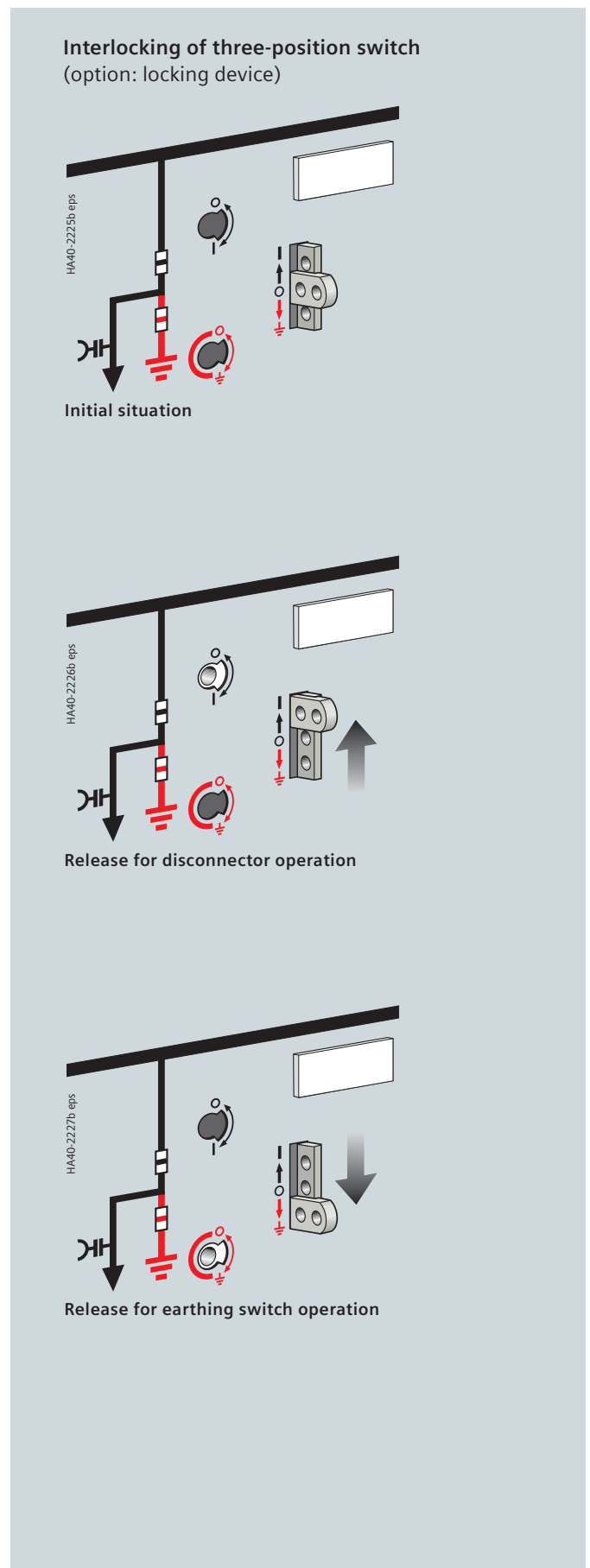

Ready-for-service indicator

Features

- Self-monitoring; easy to read
- Independent of temperature and pressure variations
- Independent of the site altitude
- Only responds to changes in gas density
- Option: Alarm switch "1NO" for remote electrical indication.

Mode of operation

For the ready-for-service indicator, a gas-tight measurement box is installed inside the switchgear vessel.

A coupling magnet, which is fitted to the bottom end of the measurement box, transmits its position to an outside armature through the non-magnetizable switchgear vessel. This armature moves the ready-for-service indicator of the switchgear.

While changes in the gas density during the loss of gas, which are decisive for the dielectric strength, are displayed, temperature-dependent changes in the gas pressure are not. The gas in the measurement box has the same temperature as that in the switchgear vessel.

The temperature effect is compensated via the same pressure change in both gas volumes.

Voltage detecting systems according to IEC/EN 61243-5 or VDE 0682-415.

- To verify safe isolation from supply
- Detecting systems
 - HR or LRM system with plug-in indicator
 - LRM system with integrated indicator, type VOIS+, VOIS R+
 - LRM system with integrated indicator, integrated repeat test of the interface and function test, type CAPDIS-S1+; with additional integrated signaling relay, type CAPDIS-S2+.

Gas monitoring

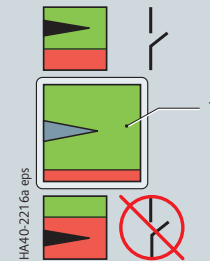

- 1 Green indication: ready for service (red indication: not ready for service)

Indicator on control board: ready for service

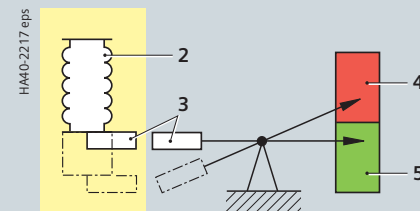

Stainless-steel vessel filled with SF₆ gas, relative pressure 500 hPa at 20 °C

Ready-for-service indicator

Principle of operation of gas monitoring with ready-for-service indicator

- 2 Measurement box
3 Magnetic coupling
4 Red indication: not ready for service
5 Green indication: ready for service

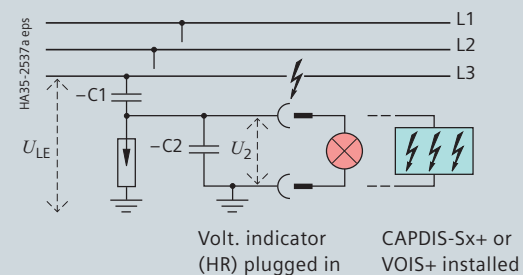

Voltage indication

via capacitive voltage divider (principle)

- C₁ Capacitive coupling electrode integrated into bushing
- C₂ Capacity of the coupling unit (as well as connection leads of the voltage detecting system) to earth

$$U_{LE} = U_N / \sqrt{3} \text{ during rated operation in the three-phase system}$$

U₂ Voltage at the interface (for plug-in voltage detecting system) or at the test socket (for integrated voltage detecting system)

Components

Indicating and measuring equipment

Plug-in voltage indicator

- Verification of safe isolation from supply phase by phase through insertion in each socket pair
- Indicator suitable for continuous operation
- Safe-to-touch
- Routine-tested
- Measuring system and voltage indicator can be tested
- Voltage indicator flashes if high voltage is present
- Degree of protection IP 54, temperature range – 25 °C to + 55 °C.

VOIS+, VOIS R+

- Integrated display, without auxiliary power
- With indication "A1" to "A3" (see legend)
- Maintenance-free, repeat test required
- With integrated 3-phase test socket for phase comparison (also suitable for plug-in voltage indicator)
- Degree of protection IP 54, temperature range – 25 °C to + 55 °C
- With integrated signaling relays (only VOIS R+)
 - "M1": Voltage present at one phase L1, L2 or L3 as a minimum
 - "M2": Voltage not present at L1, L2 and L3.

CAPDIS-Sx+

Common features

- Maintenance-free
- Integrated display, without auxiliary power
- Integrated repeat test of the interfaces (self-monitoring)
- With integrated function test (without auxiliary power) by pressing the "Device-Function-Test" pushbutton
- With integrated, 3-phase test socket for phase comparison (also suitable for plug-in voltage indicator)
- Degree of protection IP 54, temperature range – 25 °C to + 55 °C.

Features of CAPDIS-S1+

- Without auxiliary power
- With indication "A1" to "A5" (see legend)
- Without ready-for-service monitoring
- Without signaling relay (thus without auxiliary contacts).

Features of CAPDIS-S2+

- With indication "A0" to "A6" (see legend)
- Only by pressing the "Device-Function-Test" pushbutton: "ERROR" indication (A6), e.g. in case of missing auxiliary voltage
- With ready-for-service monitoring (external auxiliary power required)
- With integrated signaling relay for signals "M1" to "M4" (auxiliary power required):
 - "M1": Voltage present at phases L1, L2 and L3
 - "M2": Voltage not present at phases L1, L2 and L3 (= active zero indication)
 - "M3": Earth fault or voltage failure, e.g. in one phase
 - "M4": External auxiliary power missing (with operating voltage present or not).

Indicator and detecting systems



Plug-in voltage indicator per phase at the panel front



Integrated voltage indicator VOIS+, VOIS R+

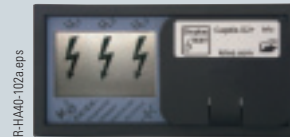

Integrated voltage indicator CAPDIS-S1+, -S2+

Symbols shown

	VOIS+, VOIS R+			CAPDIS-S1+			CAPDIS-S2+		
	L1	L2	L3	L1	L2	L3	L1	L2	L3
A0							000		
A1	⚡	⚡	⚡	⚡	⚡	⚡	⚡	⚡	⚡
A2									
A3		⚡	⚡		⚡	⚡		⚡	⚡
A4				⚡	⚡	⚡	⚡	⚡	⚡
A5				000	000	000	000	000	000
A6							000	000	000 ERROR

- A0** CAPDIS-S2+: Operating voltage not present
- A1** Operating voltage present
- A2** – Operating voltage not present,
 - for CAPDIS-S2+: Auxiliary power not present
- A3** Failure in phase L1, operating voltage at L2 and L3 (for CAPDIS-Sx+ also earth-fault indication)
- A4** Voltage (not operating voltage) present
- A5** Indication "Device-Function-Test" passed
- A6** Indication "ERROR", e.g.: in case of missing auxiliary voltage (see: "Error indication M4")

Verification of correct terminal-phase connections

- Verification of correct terminal-phase connections possible by means of a phase comparison test unit – can be ordered separately
- Safe-to-touch handling of the phase comparison test unit by inserting it into the capacitive taps (socket pairs) of the switchgear and / or feeders.

Phase comparison test units



Make Pfisterer, type EPV

- For plug-in voltage detecting systems (HR and LRM)
- For integrated voltage detecting systems (CAPDIS-S1+, -S2+)

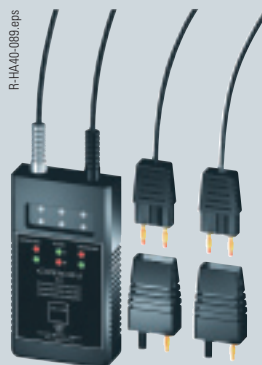

Make Horstmann, type ORION 3.0

as combined test unit for:

- Phase comparison
- Interface testing at the switchgear
- Voltage detection for HR and LRM systems



Make Kries, type CAP-Phase

as combined test unit (HR and LRM) for:

- Voltage detection
- Repeat test
- Phase comparison
- Phase sequence test
- Self-test

The unit does not require a battery

or other makes

Components

Indicating and measuring equipment

Short-circuit/earth-fault indicator (option)

All ring-main feeders can be optionally equipped with a 3-phase short-circuit or earth-fault indicator.

Features

- Use depends on network conditions
- Optical signal when a preselected pickup value is exceeded
- Depending on the type, reset
 - Manually
 - Automatically after a preset time (e.g. 2 h)
- With ring-type sensors
- Display unit, withdrawable housing, depending on the type
- Pickup values are adjustable (depending on the type of device)
- Options:
 - Remote electrical indication via contact (1 NO + 1 NC) adjustable as passing contact (W) or maintained contact (D), depending on the type of device.



Selection of short-circuit/earth-fault indicators

Indicator type ¹⁾	Reset		Remote reset: A: By aux. voltage B: Via NO contact (floating)	Automatic reset after return of auxiliary voltage supply	Pickup values Short-circuit current I_K (A) Standard, other values on request	Pickup values Earth-fault current I_E (A) Standard, other values on request	Opt.: Remote ind. as W (passing contact = standard) D (maintained contact = option)
	manually	automatically after					

Short-circuit indicator

ALPHA M ⁵⁾	x	–	–	–	400, 600, 800, 1000	–	W, D
ALPHA E ⁵⁾	x	2 h or 4 h	A (12–60 V AC / DC)	–	400, 600, 800, 1000	–	W, D
Opto F3.0 ^{3) 5)}	x	after 1, 2, 4, 8 h	B (1NO)	–	400, 600, 800, 1000	–	W, D
SIGMA	x	after 1, 2, 4, 8 h	B (1NO)	–	300, 400, 600, 800, 1000, ⁸⁾	–	W, D
SIGMA ACDC ^{2) 5)}	x	after 1, 2, 4, 8 h	B (1NO)	x (adjustable)	300, 400, 600, 800, 1000, ⁸⁾	–	W, D
IKI-20-B1 ⁶⁾	x	after 2 h or 4 h	B (1NO)	–	400, 600, 800, 1000	–	W, D
IKI-20-T1 ⁶⁾	x	nach 2 h or 4 h	B (1NO)	x (50 / 60 Hz, 110–230 V AC)	400, 600, 800, 1000	–	W, D

Earth-fault/short-circuit indicator

EKA-3 ^{4) 5)}	–	–	–	x (50 Hz, 230 V AC) ⁴⁾	450	40, 80, 160	W, D
SIGMA F+E ⁵⁾	x	after 1, 2, 4, 8 h	B (1NO)	–	300, 400, 600, 800, 1000, ⁸⁾	adjustable	W, D
SIGMA F+E ^{2) 5)} ACDC	x	after 1, 2, 4, 8 h	B (1NO)	x (adjustable)	300, 400, 600, 800, 1000, ⁸⁾	adjustable	W, D
DELTA E ⁵⁾	x	after 2 h or 4 h	A (12–60 V AC / DC)	–	400, 600, 800, 1000	200	W, D
Opto F+E3.0 ^{3) 5)}	x	after 1, 2, 4, 8 h	B (1NO)	–	400, 600, 800, 1000	40, 80, 120, 160	W, D
IKI-20-B1 ^{6) 7)}	x	after 2 h or 4 h	B (1NO)	–	400, 600, 800, 1000	10% or 25% of I_K	W, D
IKI-20-T1 ^{6) 7)}	x	after 2 h or 4 h	B (1NO)	x (50 / 60 Hz, 110–230 V AC)	400, 600, 800, 1000	10% or 25% of I_K	W, D

Earth-fault indicator

EKA-3/1 ^{2) 4) 5)}	–	–	–	x (50 Hz, 230 V AC) ⁴⁾	–	40, 80, 160	W, D
Opto E3.0 ^{3) 5)}	x	after 1, 2, 4, 8 h	B (1NO)	–	–	40, 80, 120, 160	W, D
IKI-20-T1 ^{6) 7)}	x	after 2 h or 4 h	B (1NO)	x (50 / 60 Hz, 110–230 V AC)	–	30, 55, 80, 100	W, D

For footnotes see page 51.

Application with vacuum circuit-breaker

Protection of distribution transformers with ratings that cannot or should not be protected with HV HRC fuses:

- Tripping of the circuit-breaker in case of overload (delayed)
- Tripping of the circuit-breaker when the short-circuit current arises.

Application for switch-fuse combination

Monitoring of the overload range of distribution transformers with

- Tripping of the switch in case of overload (current smaller than the rated current of the switch)
- Blocking of the tripping function in the short-circuit range (here, the fuse takes over the disconnecting function)

Transformer monitor IKI-30

- Current-transformer operated, alternatively auxiliary voltage 24 to 230 V AC/DC
- Instrument transformers
 - Special cable-type current transformers
 - No direction-dependent installation required
 - No earthing of a transformer pole required
 - No short-circuit terminals required for maintenance
- Low-energy magnetic release (0.01 Ws)
- Optional shunt release for auxiliary voltage supply
- Mounting location
 - In the front operating mechanism box of the feeder panel
 - In the low-voltage compartment (option) of the circuit-breaker feeder
- Response performance
 - Definite-time overcurrent characteristic
 - Definite-time overcurrent characteristic for earth-fault protection
 - Inverse-time overcurrent characteristic
 - extremely inverse
 - normal inverse
 - Externally undelayed instantaneous tripping
- Self-test function
 - Display test LED (red)
 - Battery test (under load), LED (green)
 - Primary current test with tripping and with primary current injection into the transformers
- Indication
 - LED indication for tripping (single flash: starting, double flash: tripping)
 - Reset after 2 h or automatically (after return of power) or manually with reset pushbutton

Example for selection of transformer protection

Operating voltage (kV)	Transformer rating (kVA)		
	7SJ45 / 7SJ46	WIC 1-2P	IKI-30
6	≥ 160	≥ 160	≥ 160
10	≥ 200	≥ 250	≥ 160
13.8	≥ 250	≥ 400	≥ 160
15	≥ 315	≥ 400	≥ 160
20	≥ 400	≥ 500	≥ 250



Transformer monitor IKI-30

- Outputs
 - Tripping signal: 1 floating relay output (NC contact) for telecommunication as passing contact
 - Starting signal: 1 floating relay output (NC contact) – is activated as long as the starting criterion is reached, e.g. to block an upstream primary protection
 - 1 watchdog (relay)
 - 1 external tripping output for control of an existing release, e.g. via capacitor
 - Tripping output designed as impulse output for direct control of the low-energy release
- Input
 - Remote tripping signal, control via floating external contact
 - Instantaneous tripping.

Footnotes for page 50

- | | | |
|--|--|---------------------------------|
| 1) Further types on request | 4) External auxiliary voltage required (230 V AC, 50 Hz), device with integrated battery (capacity for approx. 10 h) | 7) Ring-type sensor: d = 110 mm |
| 2) External auxiliary voltage required (12–60 V DC or 110–230 V AC) | 5) Make Horstmann | 8) Or self-adjustment |
| 3) Power supply required for the LED indication (integrated lithium cell, alternatively 12–110 V DC or 24–60 V AC) | 6) Make Kries Energietechnik | |

Components

Protection systems

Simple protection systems

As a simple protection for distribution transformers and circuit-breaker feeders, standard protection systems are available, consisting of:

- Current-transformer operated protection device with c.t.-operated release (low-energy 0.1 Ws)
 - Siemens 7SJ45
 - Woodward/SEG WIC 1-2P, WIC 1-3P, WIP-1
- Protection device with auxiliary voltage supply with shunt release (f)
 - Siemens 7SJ46
- Instrument transformer as
 - Cable-type current transformer (standard)
 - Three-phase current transformer as option for 8DJH switchgear panels L(500).

Mounting location

- In 200-mm-high top low-voltage unit (option) of the circuit-breaker feeder.

Multifunction protection (selection)

SIPROTEC multifunction protection

Common features

- User-friendly operating program DIGSI 4 for parameterizing and analysis
- Freely programmable LEDs for displaying any desired data
- Communications and bus capability
- Functions: Protection, control, indicating, communications and measuring
- Operation and fault indication memory.

7SJ600/7SJ602

- LC text display (2 lines) and keyboard for local operation, parameterizing and indication
- Control of the circuit-breaker.

7SJ80

- LC text display (6 lines) and keyboard for local operation, parameterizing and indication
- Control of circuit-breaker and disconnecter.

7SJ61/7SJ62/7SJ63

- For stand-alone or master operation
- LC text display (4 lines) for process and equipment data
- Four freely programmable function keys for frequently performed functions
- Keys for navigation in menus and for entering values.

Additionally for 7SJ63

- Graphical LCD for process and equipment data in the form of a feeder mimic diagram and as text
- Fourteen freely programmable LEDs for displaying any desired data
- Two key-operated switches to switch between “local and remote control” and “interlocked and non-interlocked operation”
- Integrated motor control by special relays with enhanced performance.



Other types and makes on request

Mounting location

- In the 600-mm or 900-mm-high low-voltage compartment (option) of the circuit-breaker feeder.

Components

Low-voltage compartment

Features

- Overall heights
 - 200 mm, 400 mm, 600 mm, 900 mm
 - Option: Cover
- Partitioned safe-to-touch from the high-voltage part of the panel
- Installation on the panel:
 - Possible per feeder
 - Standard for circuit-breaker panel type L (1.1) and bus sectionalizer panels with switch-disconnector
 - Option for all other panel types, depending on the configuration of the secondary equipment
- Customer-specific equipment
 - For accommodation of protection, control, measuring and metering equipment
- Separate wiring duct on the switchgear beside the low-voltage compartment (option)
- Door with hinge on the left (standard for heights of 400, 600 and 900 mm).

Low-voltage cables

- Control cables of the panel to the low-voltage compartment via multi-pole, coded module plug connectors
- Option: Plug-in bus wires from panel to panel in the separate wiring duct on the panel.

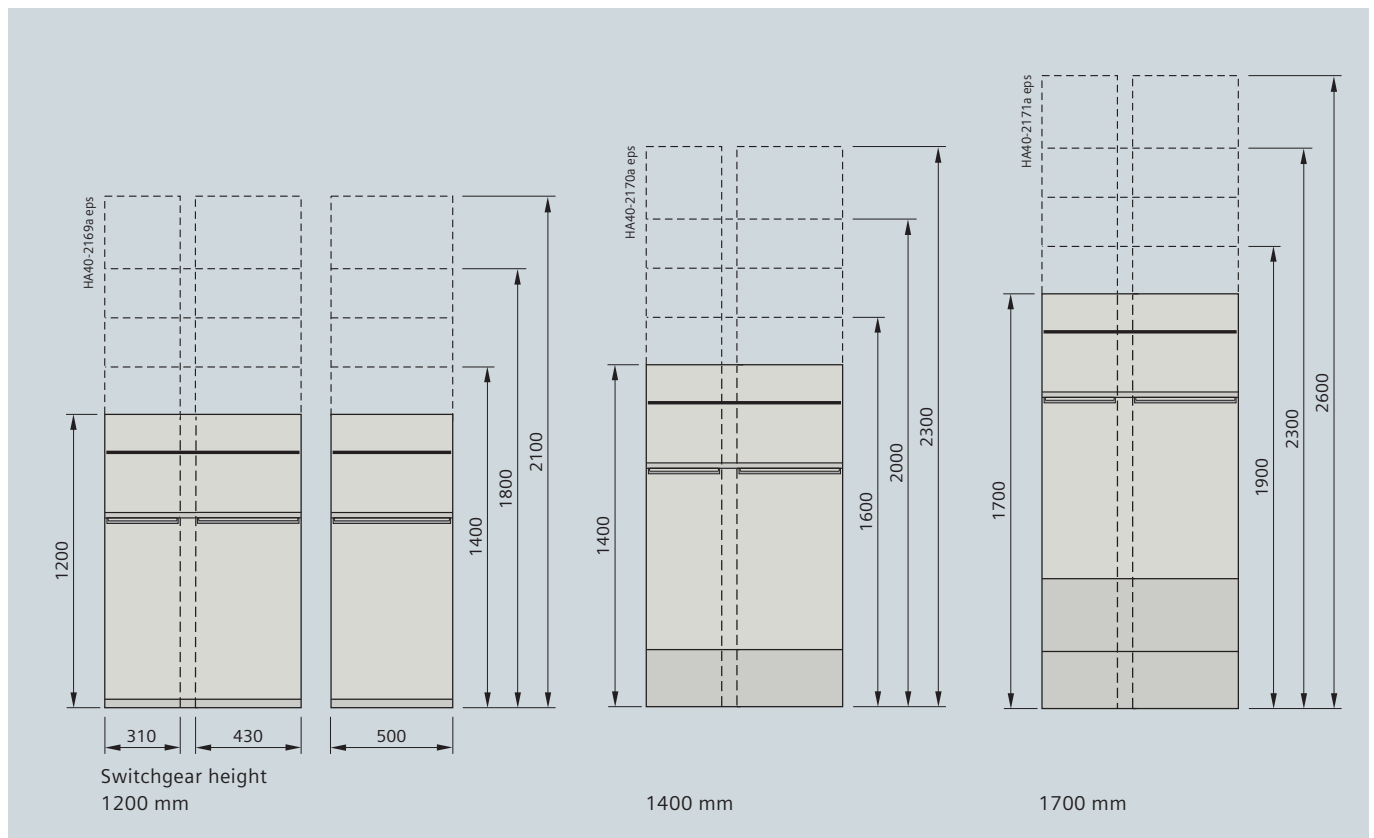
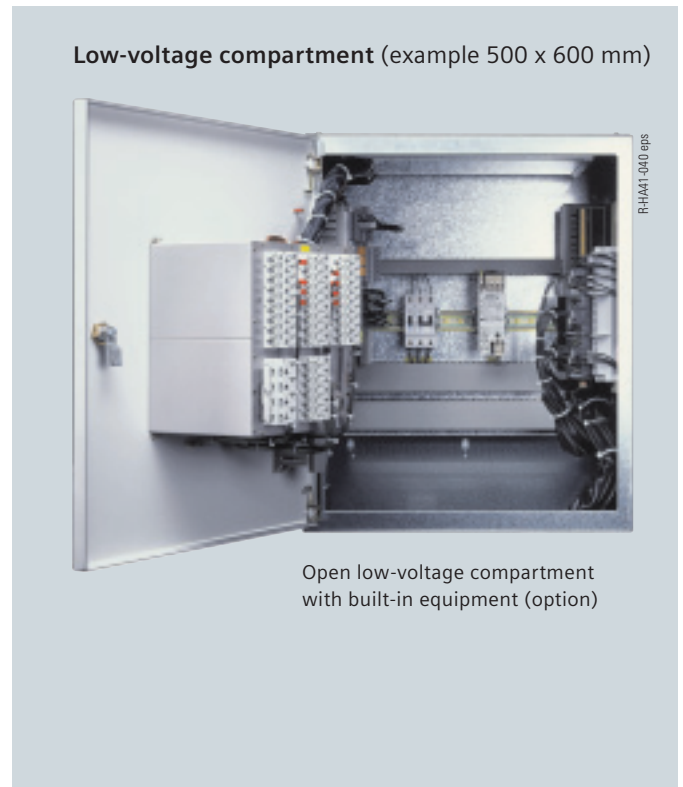

Components

Low-voltage niche

Low-voltage niche

- Only inside billing metering panels type M
- For accommodation of options, e.g.:
 - Voltage transformer m.c.b.'s
 - Small distribution fuse-box and fuse-links type Diazed or Neozed.

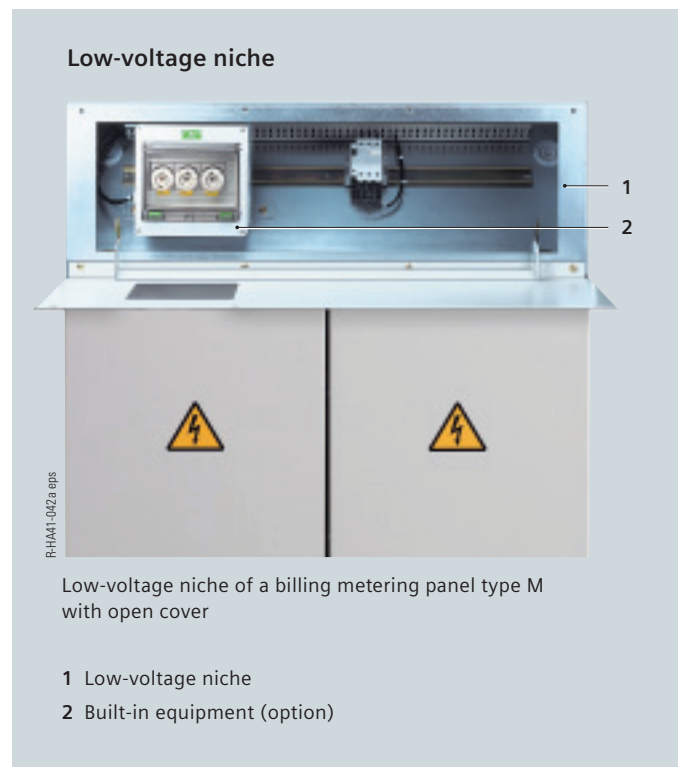

Dimensions

Individual panels and modules

Cable feeder type K

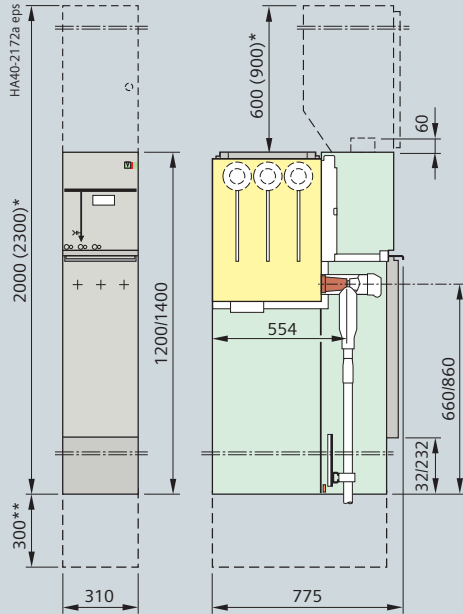

Ring-main feeder type R

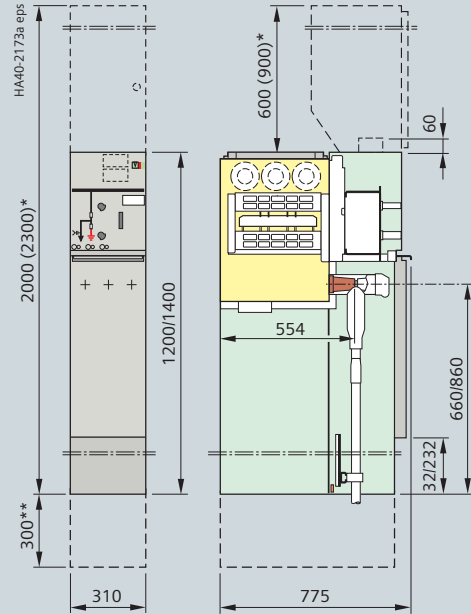

Transformer feeder type T

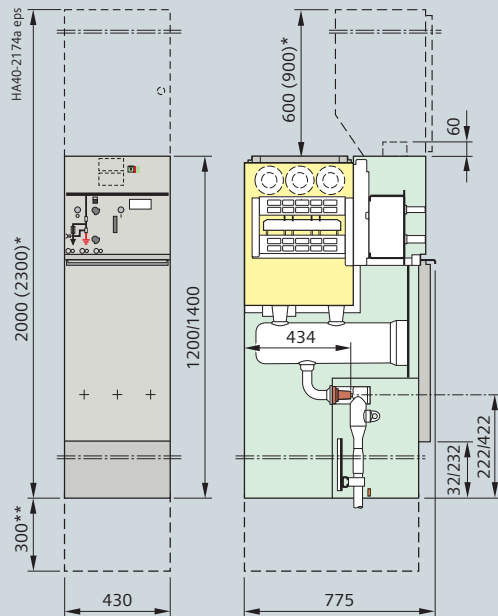

Circuit-breaker feeder type L

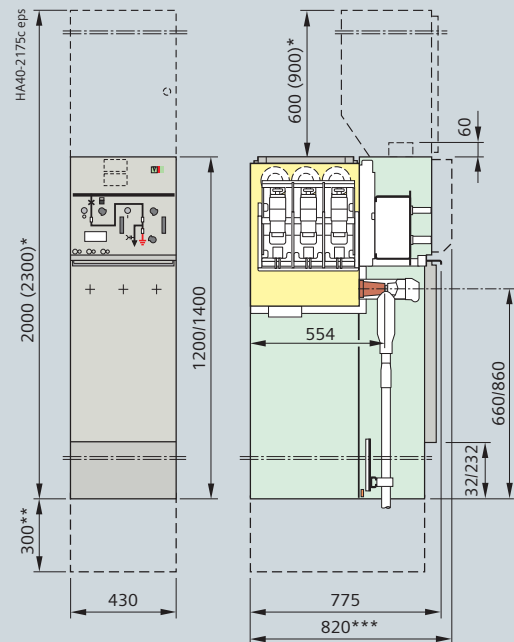

*) Option: With low-voltage compartment

***) Base for switchgear height of 1700 mm

***) Only for circuit-breaker type 1.1

Dimensions

Circuit-breaker feeders as individual panels (500 mm)

Circuit-breaker feeder type L(500) – type 2

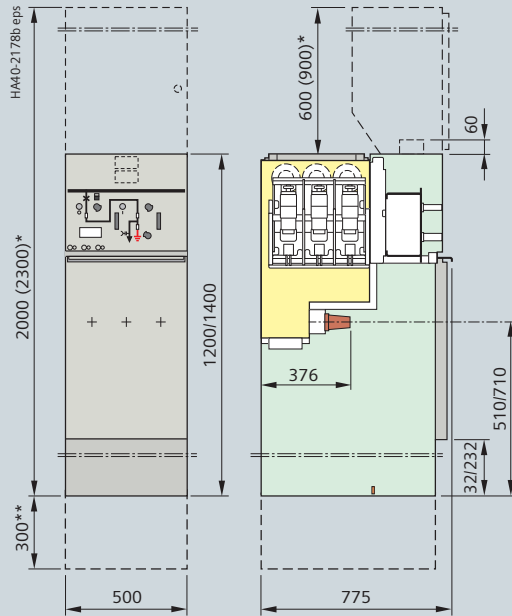

Design option with busbar voltage transformers for all circuit-breaker types

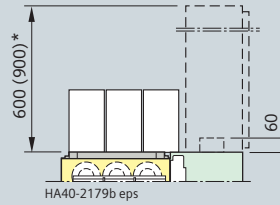

Circuit-breaker feeder type L(500) – type 1.1

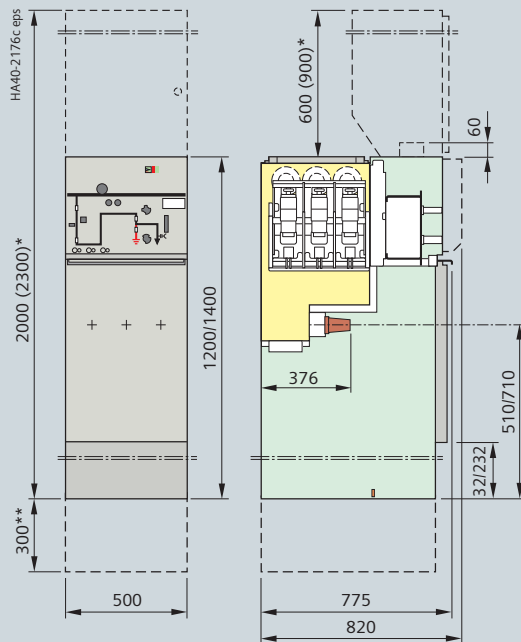

*) Option: With low-voltage compartment

***) Base for switchgear height of 1700 mm

Dimensions

Further individual panels

Ring-main feeder type R(500)

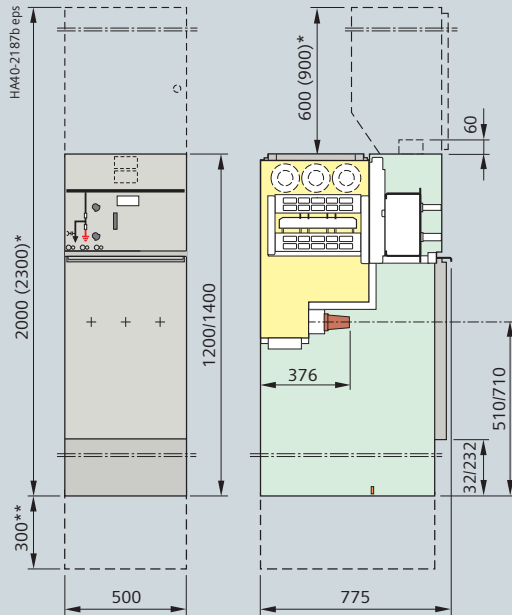

Cable feeder type K(E) with make-proof earthing switch

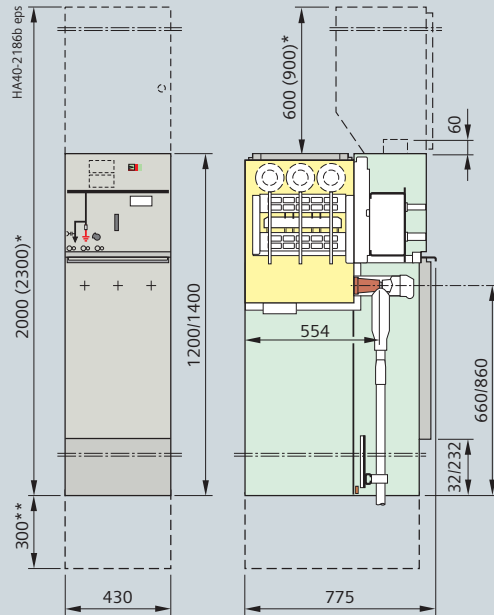

Metering panel type M(500) with disconnectable voltage transformer

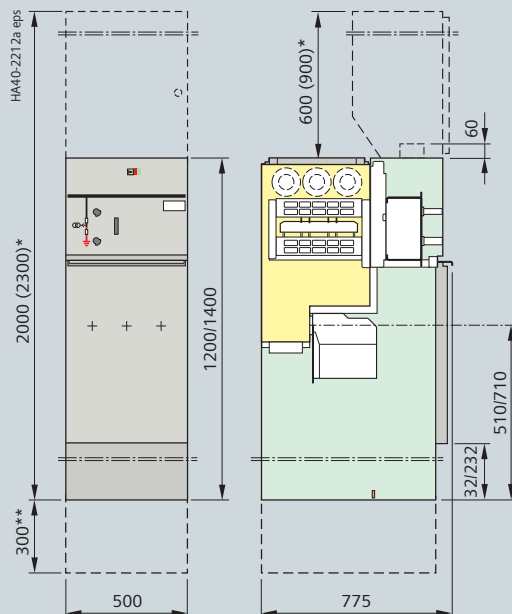

*) Option: With low-voltage compartment

***) Base for switchgear height of 1700 mm

Dimensions

Bus sectionalizer panels with switch-disconnector

Bus sectionalizer panel/module type S
with three-position switch-disconnector
and earthing on the left

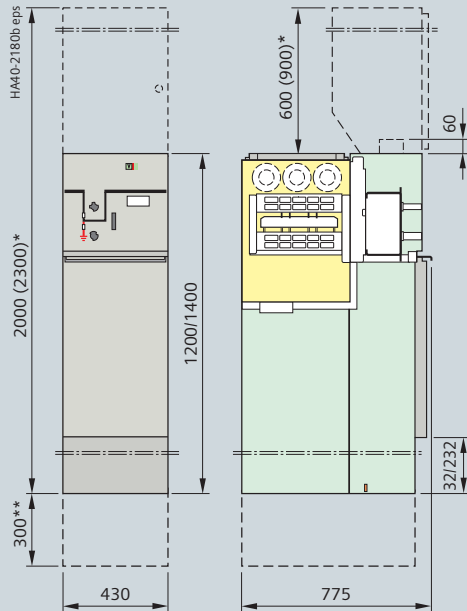

Bus sectionalizer panel/module type H
with switch-disconnector/fuse combination

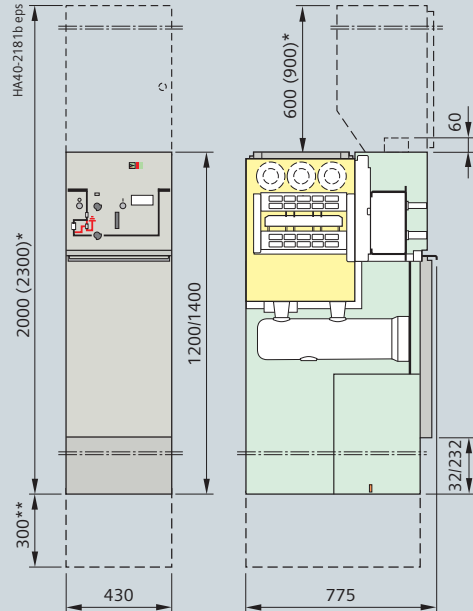

Bus sectionalizer panel/module type S(620)
with three-position switch-disconnector and earthing on the right

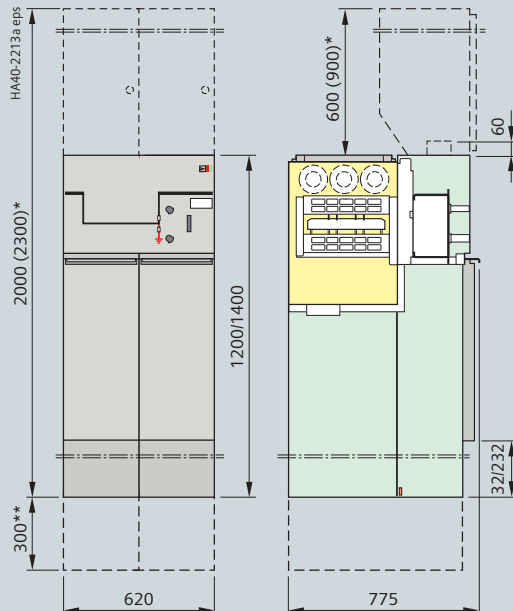

*) Option: With low-voltage compartment

***) Base for switchgear height of 1700 mm

Dimensions

Bus sectionalizer panel with circuit-breaker

Bus sectionalizer panel type V with circuit-breaker

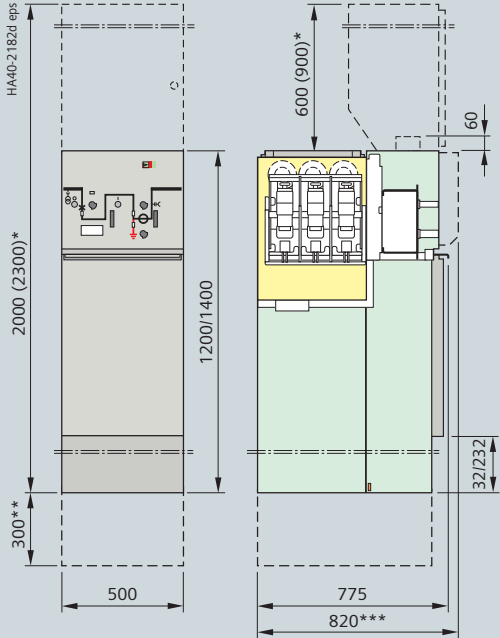

Design options with busbar voltage transformer and / or busbar current transformer

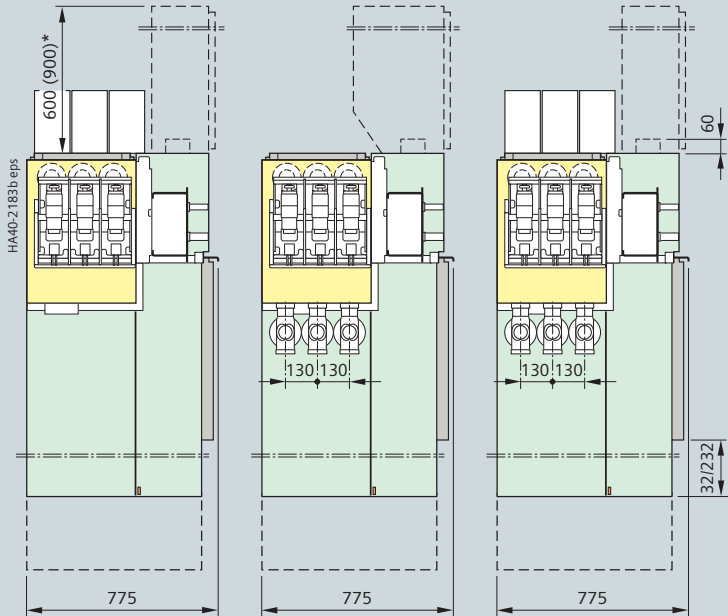

*) Option: With low-voltage compartment
 **) Base for switchgear height of 1700 mm
 ***) Only for circuit-breaker type 1.1

Dimensions

Busbar earthing panels

Busbar earthing panel type E

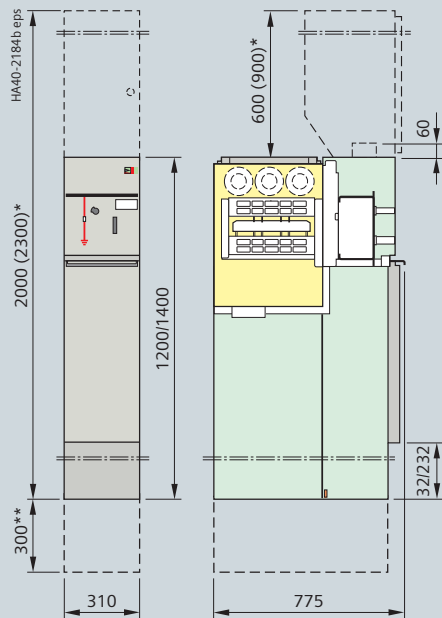

Busbar earthing panel type E(500) with voltage transformer

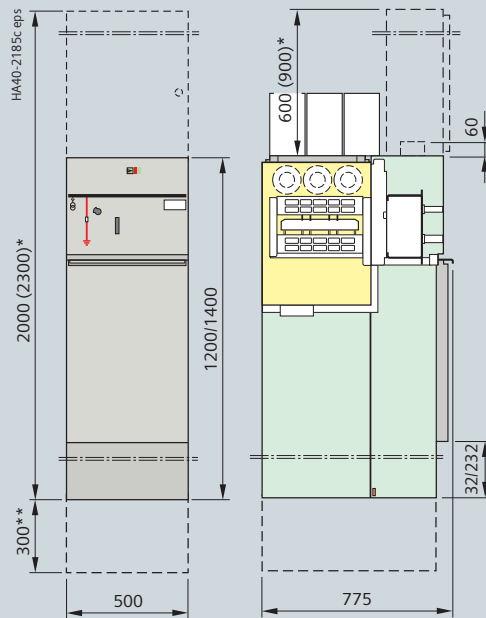

*) Option: With low-voltage compartment

***) Base for switchgear height of 1700 mm

Dimensions

Billing metering panel as individual panel, air-insulated

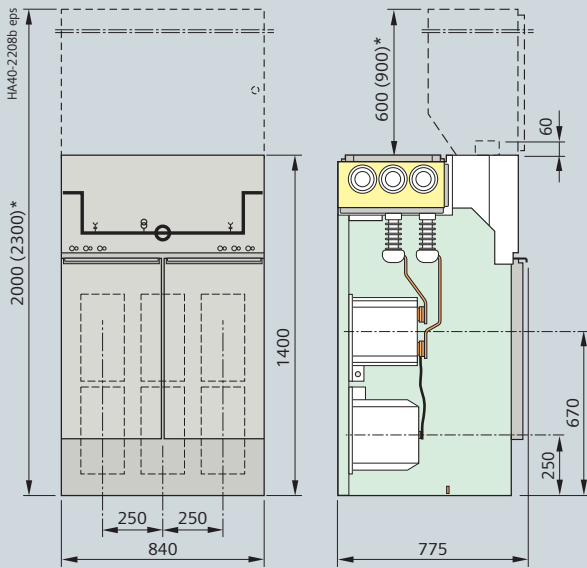

Connection: busbar – busbar

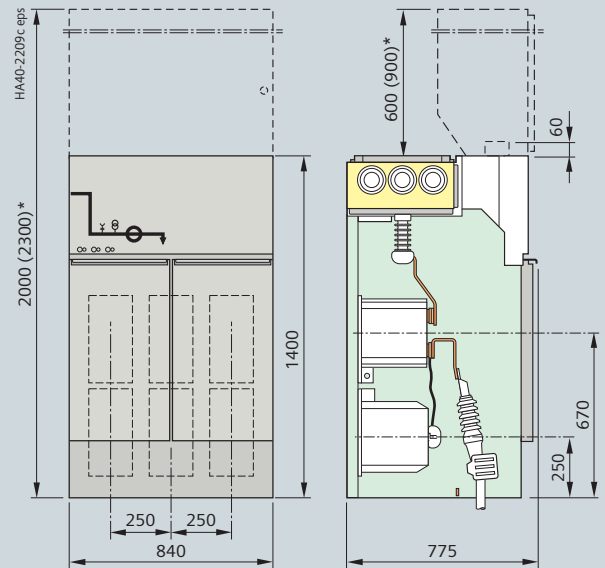

Connection: busbar on the left – cable on the right

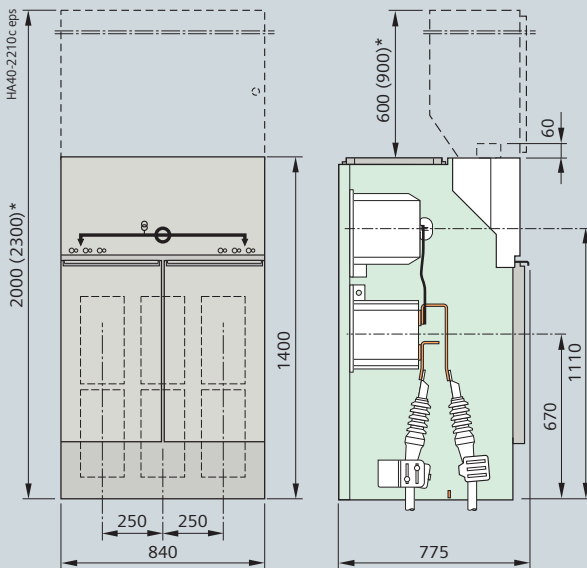

Connection: cable – cable

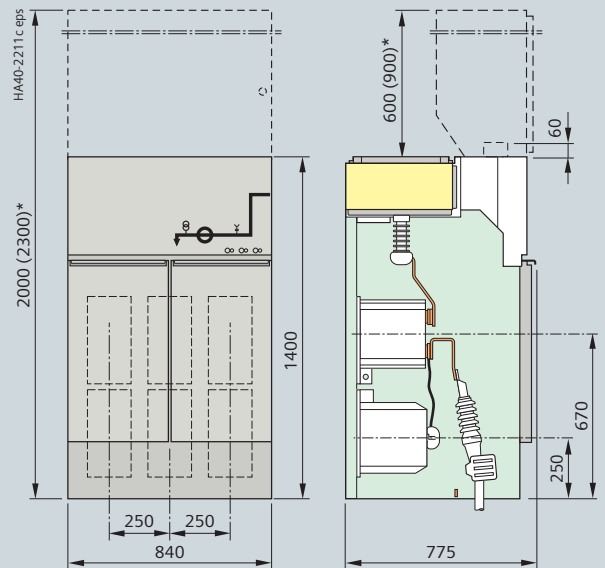

Connection: cable on the left – busbar on the right

*) Option: With low-voltage compartment

Dimensions

Preferred scheme versions in block-type construction (optionally in 3 overall heights)

Versions with transformer feeders

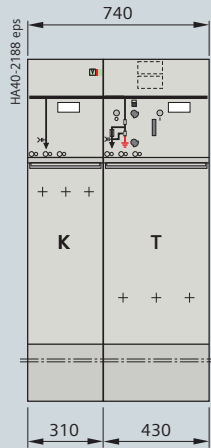

Scheme KT

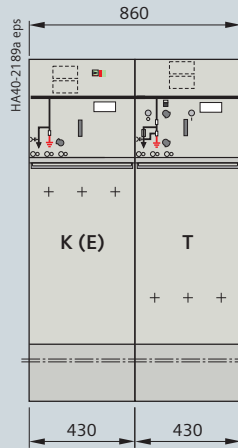

Scheme K(E)T

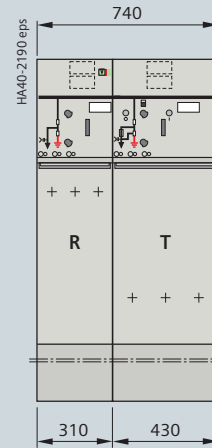

Scheme RT

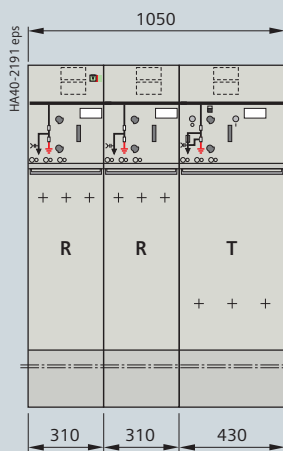

Scheme RRT

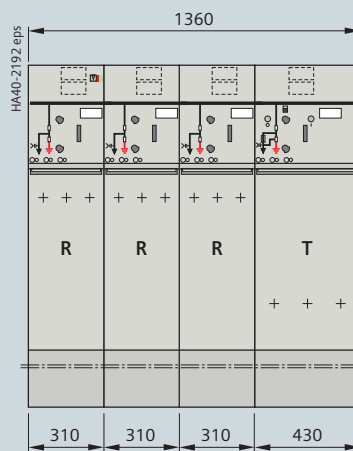

Scheme RRRT

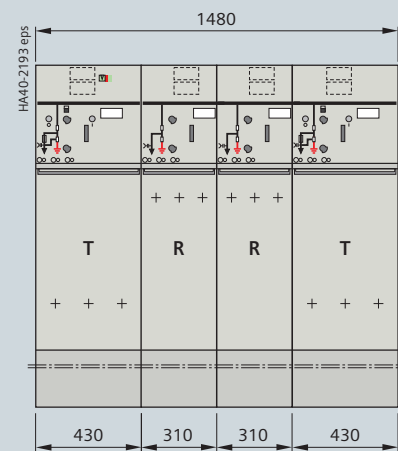

Scheme TRRT

For further dimension data, see individual panels/
individual modules on pages 55 to 57

For floor openings and fixing points,
see pages 67 to 70

Dimensions

Preferred scheme versions in block-type construction (optionally in 3 overall heights)

Versions with circuit-breaker feeders

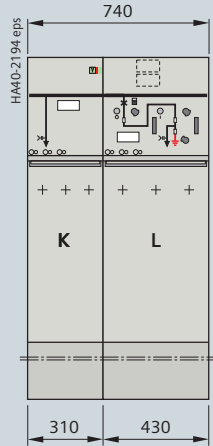

Scheme KL

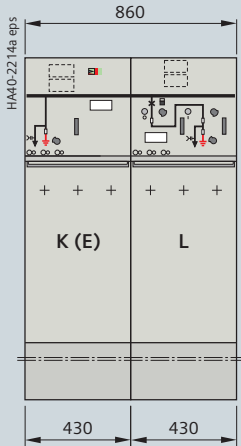

Scheme K(E)L

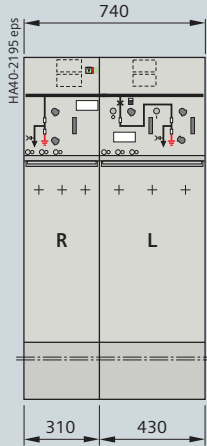

Scheme RL

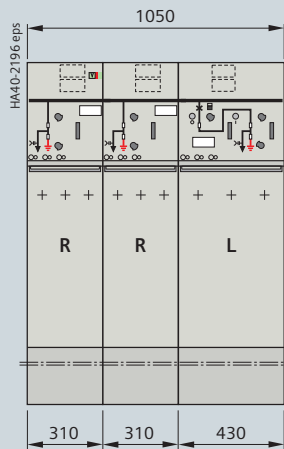

Scheme RRL

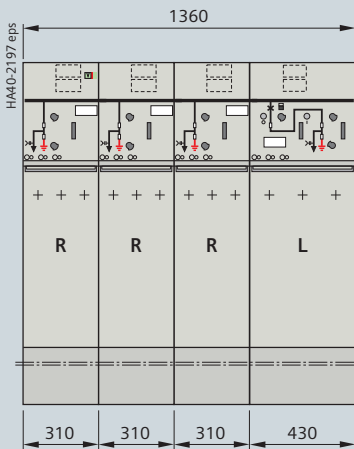

Scheme RRRL

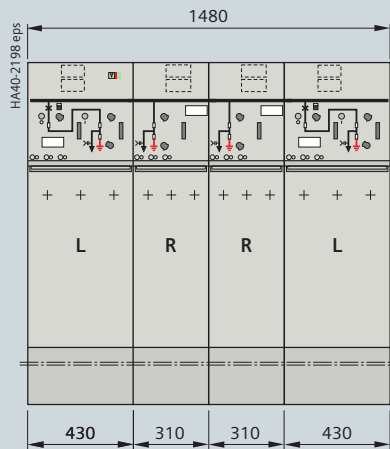

Scheme LRRL

For further dimension data, see individual panels/
individual modules on pages 55 to 57

For floor openings and fixing points,
see pages 67 to 70

Dimensions

Preferred scheme versions in block-type construction (optionally in 3 overall heights)

Further versions

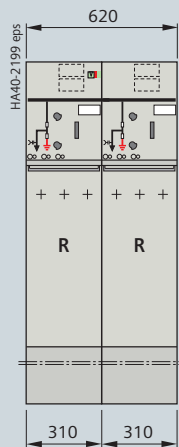

Scheme **RR**

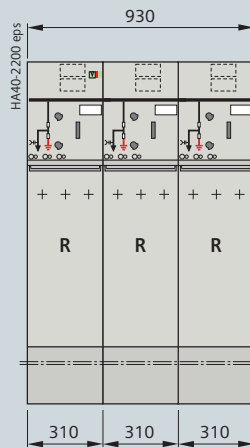

Scheme **RRR**

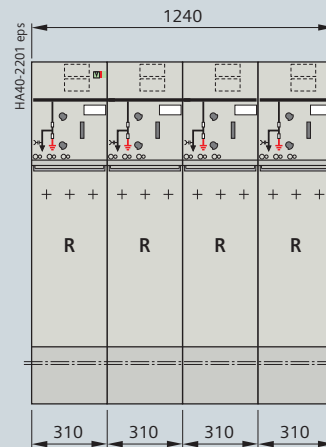

Scheme **RRRR**

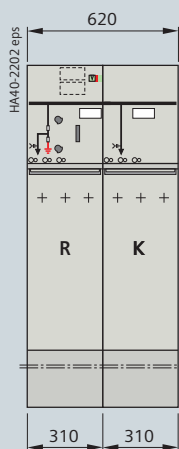

Scheme **RK**

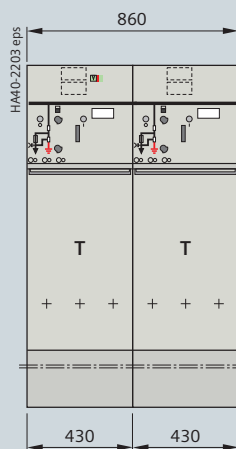

Scheme **TT**

For further dimension data, see individual panels/
individual modules on pages 55 to 57

For floor openings and fixing points,
see pages 67 to 70

Dimensions

Ring-main, cable, transformer and circuit-breaker panels in free blocks

Examples of freely configurable panel blocks

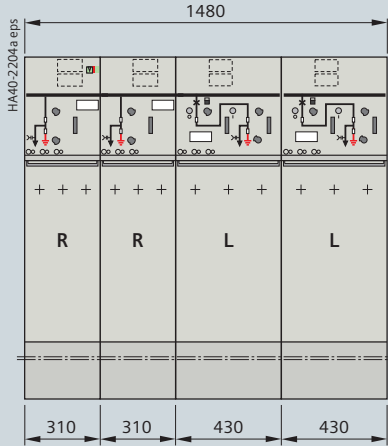

Scheme RRL

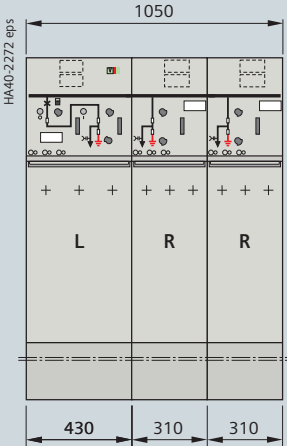

Scheme LRR

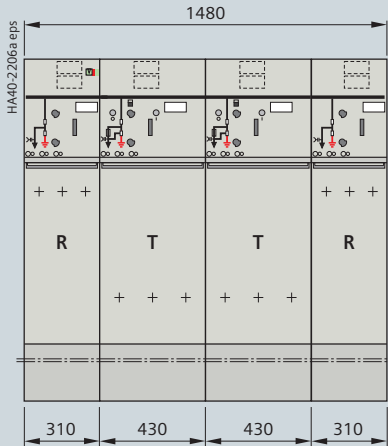

Scheme RTTR

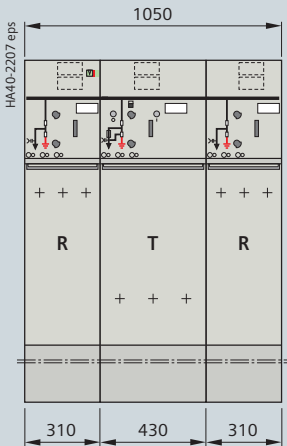

Scheme RTR

Dimensions

Panel combinations with billing metering panels (examples)

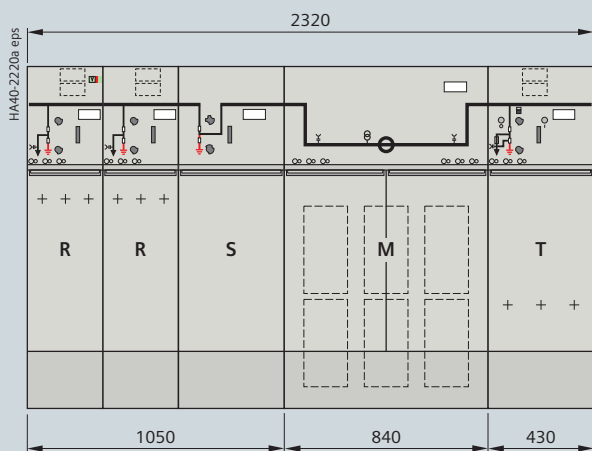

Transfer with ring-main switch (RRS-M-T...)

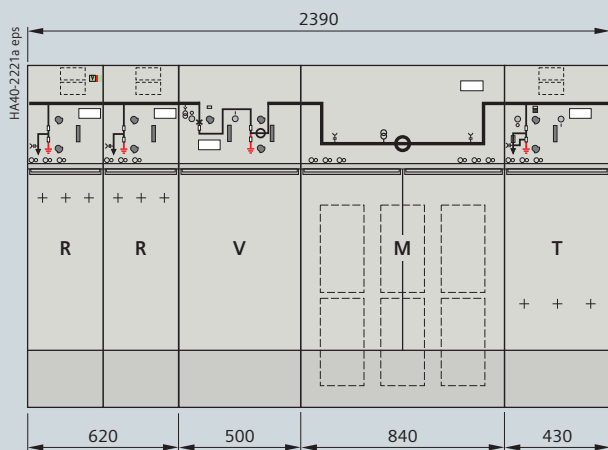

Transfer with circuit-breaker without cables (RR-V-M-T...)

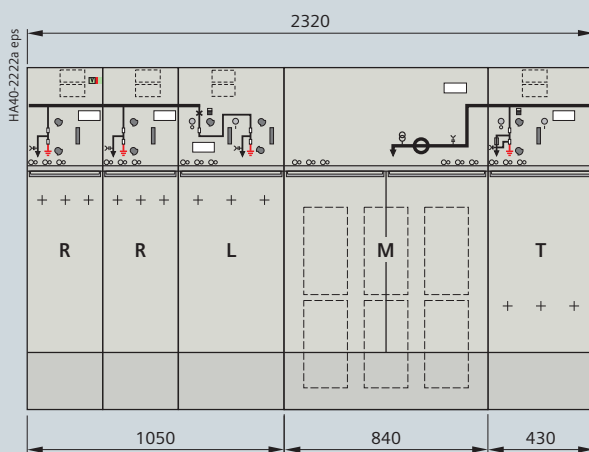

Transfer with circuit-breaker in the panel block and cable connection (RRL-M-T...)

Dimensions

Floor openings and fixing points

Standard *)

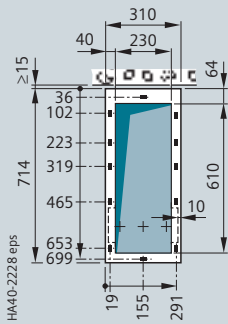

- For ring-main panel type R
- For cable panel type K
- For busbar earthing panel type E

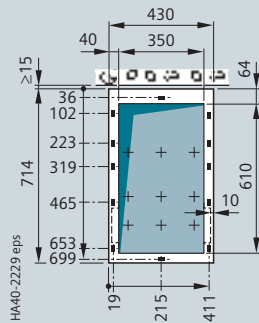

- For cable panel with make-proof earthing switch type K(E)
- For circuit-breaker panel type L
- For transformer panel type T
- For bus sectionalizer panel with switch-disconnector type S
- For bus sectionalizer panel with switch-disconnector type H

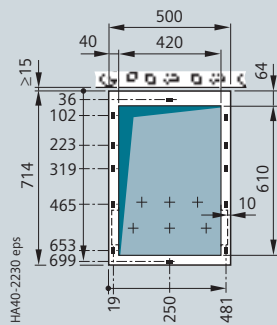

- For ring-main panel type R(500)
- For circuit-breaker panel type L(500)
- For busbar earthing panel type E(500)
- For bus sectionalizer panel with switch-diconnector type S(500)
- For bus sectionalizer panel with circuit-breaker type V
- For busbar voltage metering panel type M(500)

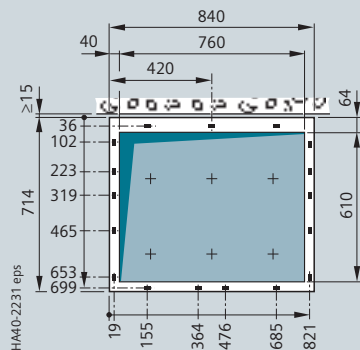

- For billing metering panel type M

*) For panel versions with double cables and deep cable compartment cover, as well as for other versions, please order the dimension drawings.

Dimensions

Floor openings and fixing points

Standard *) panel blocks

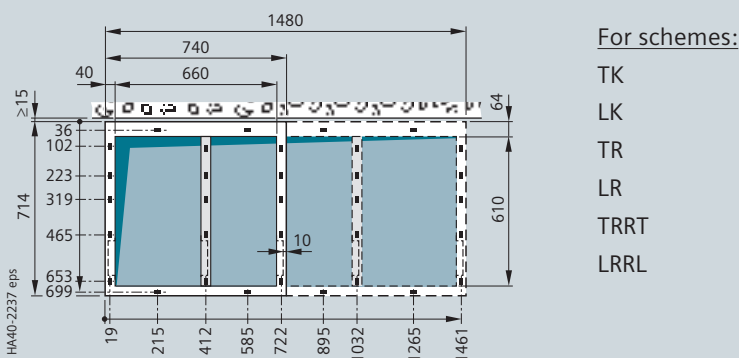
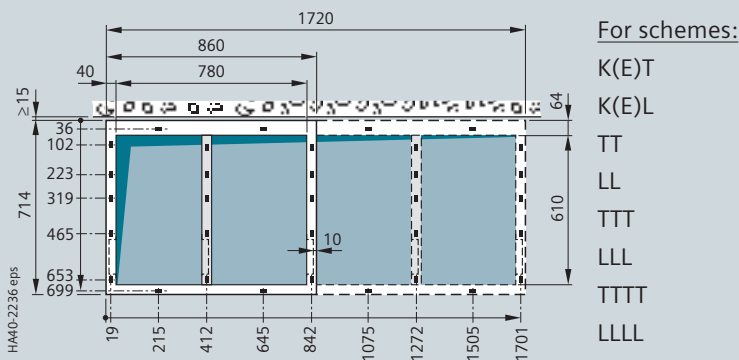
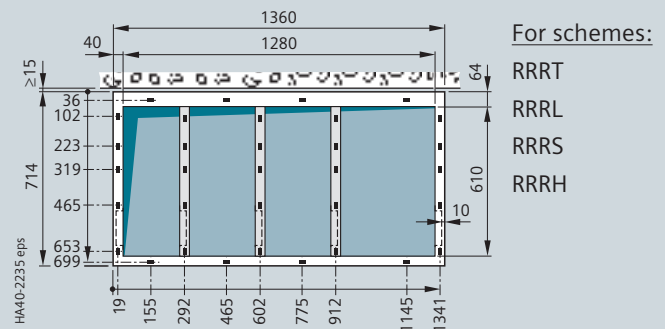
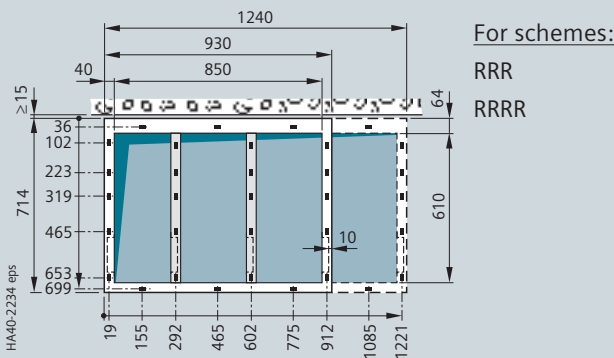
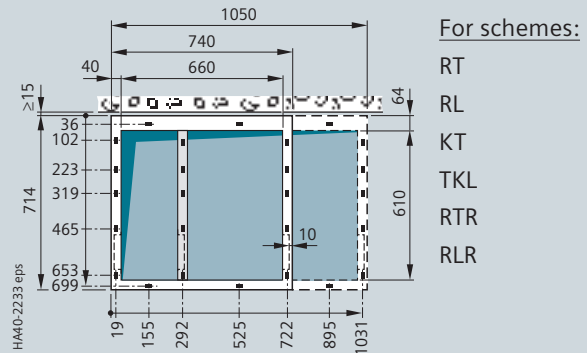
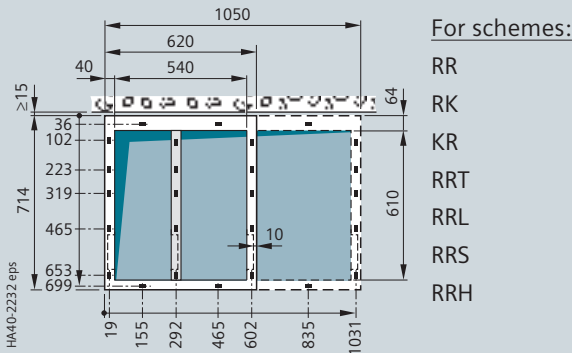

*) For panel versions with double cables and deep cable compartment cover, as well as for other versions, please order the dimension drawings.

Dimensions

Floor openings and fixing points

Versions with deep cable compartment covers (e.g. for double cable connections)

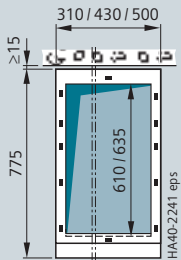

Deep cable compartment cover:
Without

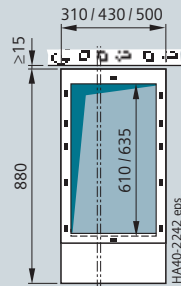

Deeper by 105 mm

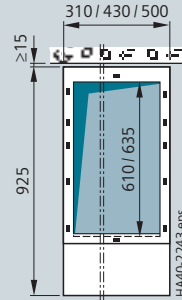

Deeper by 150 mm

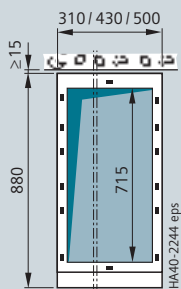

Deep cable compartment cover with
base extension:
Deeper by 105 mm

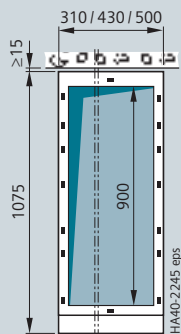

Deeper by 300 mm

Example

Position of floor openings and fixing points for double cable connection for panel blocks

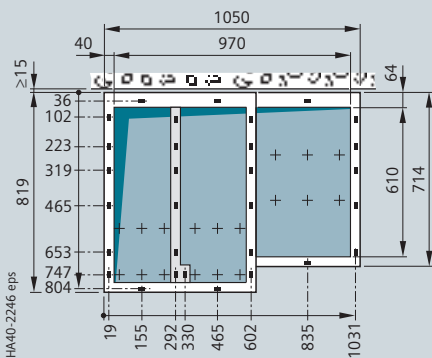

Type RRT deeper by 105 mm

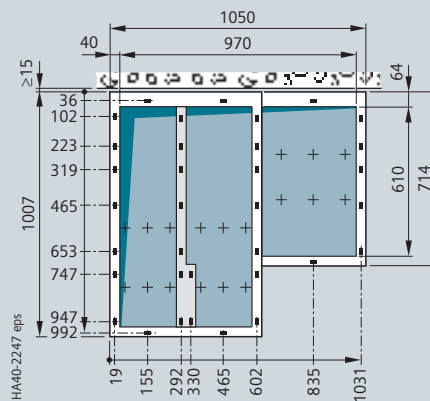

Type RRT deeper by 300 mm

Dimension drawings are required for concrete switchgear versions.

Dimensions

Floor openings and fixing points

Versions in connection with pressure absorbers and deep cable compartment covers

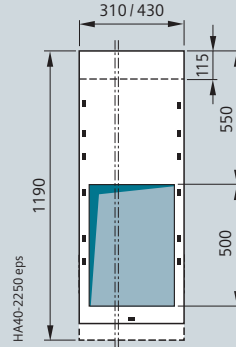
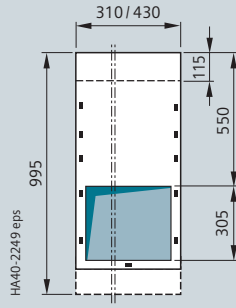
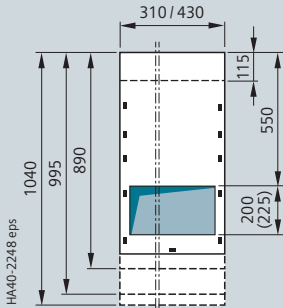

- For ring-main panel type R
- For cable panel type K
- For cable panel with make-proof earthing switch type K(E)
- For circuit-breaker panel type L

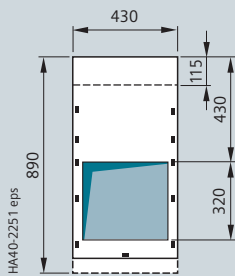

- For transformer panel type T

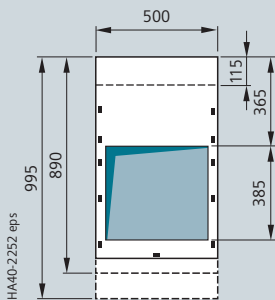

- For ring-main panel type R
- For circuit-breaker panel type L(500)

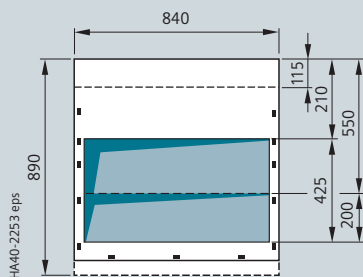

- For billing metering panel type M

Dimension drawings are required for concrete switchgear versions.

Installation

Shipping data, transport

Packing types (examples)

For size and weight of the transport units, see the following tables.

Place of destination and means of transport	Examples for packing
Germany / Europe by rail and truck	Type: Open PE protective foil pulled over the switchgear, with wooden base
Overseas by seafreight	Type: Seaworthy crate (standard) Welded PE protective foil, with closed wooden crate, with desiccant bag
	Type: Open for container PE protective foil pulled over the switchgear, with wooden base
Overseas by airfreight	Type: Open PE protective foil pulled over the switchgear, with wooden base and lattice or cardboard cover

Transport

8DJH switchgear is completely delivered in transport units. Please observe the following:

- Transport facilities on site
- Transport dimensions and weights
- Size of door openings in building
- Switchgear with low-voltage compartment: Please observe other transport dimensions and weights.

Transport dimensions

for Europe and overseas

Max. width of switchgear unit	Transport dimensions				
	Width B	Europe Height	Depth T	Overseas Height	Depth T
TE					
mm	m	m	m	m	m
850	1.10	A + 0.20	1.10	A + 0.4	1.15
1200	1.45			min. 2.00	
1550	1.80				
1800	2.05				
2000	2.55				

A = Switchgear height with or without low-voltage compartment

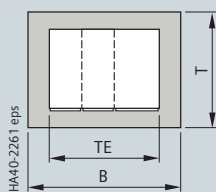

Transport units for shipment (top view)

Types of transport (examples)

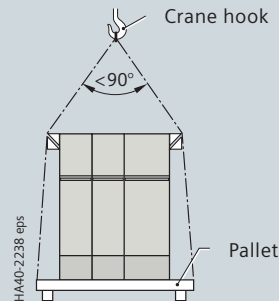

Crane transport with pallet

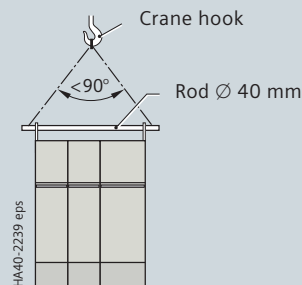

Crane transport with rod

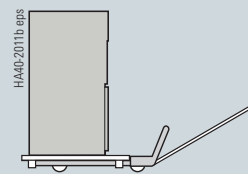

Transport with lifting truck with or without pallet

Rod \varnothing 40 mm
(observe switchgear weight)

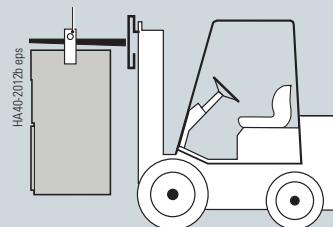

Transport with fork-lift truck, suspended

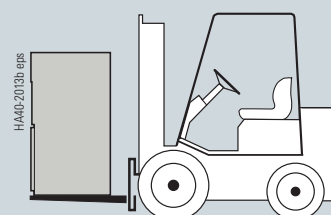

Transport with fork-lift truck, standing

Installation

Shipping data, transport

Transport weights

The transport weight results from the switchgear weight per transport unit and the packing weight. The packing weight results from the transport dimensions and the type of transport.

Packing weights

Max. width of switchgear unit mm	Packing weight for Europe approx. kg	Packing weight for overseas approx. kg
850	30	90
1200	40	120
1550	50	150
1800	60	180
2000	75	225

Switchgear weights

The weight of the switchgear unit results from the sum of the weights per functional unit. Depending on the design and the degree to which it is equipped (e.g. current transformers, motor operating mechanism, low-voltage compartment), different values will result. The table shows mean values.

Panel type	Width mm	Gross weight for a switchgear height of			LV compartment
		1200 mm approx. kg	1400 mm approx. kg	1700 mm approx. kg	600 mm approx. kg
R	310	100	110	120	40
R(500)	500	140	150	170	60
K	310	100	110	120	40
K(E)	430	130	140	160	50
T	430	135	145	160	50
L	430	130	140	155	50
L (type 1.1) without 4MT3	500	210	220	240	60
L (type 2)	500	160	170	190	60
M (SK/SS/KS)	840	–	370	400	70
M (KK)	840	–	270	300	70
M(500) incl. 3x4MT3	500	230	240	260	60
S	430	130	140	160	50
S(500)	500	150	160	180	60
S(620)	620	200	220	240	2x40
H	430	135	145	160	50
V	500	240	250	270	60
E	310	100	110	120	40
E(500)	500	140	150	170	60

Panel block	Width mm	Gross weight for switchgear height without LV compartment		
		1200 mm approx. kg	1400 mm approx. kg	1700 mm approx. kg
KT, KT	740	230	250	280
K(E)T	860	240	260	290
KL* , LK	740	230	250	280
K(E)L*	860	250	270	300
RK, KR	620	200	220	240
RT, TR	740	230	250	280
RL* , LR	740	230	250	280
TT	860	270	290	320
RR	620	200	220	240
LL*	860	260	280	310
RS	740	230	250	280
RH	740	230	250	280
RRT	1050	330	360	400
RRL*	1050	320	350	390
RTR	1050	330	360	400
RLR	1050	320	350	390
RRR	930	300	330	360
TTT	1290	410	440	490
LLL*	1290	400	430	480
RRS	1050	320	350	390
RRH	1050	330	360	400
RRRT	1360	430	470	520
RRRL*	1360	430	470	520
RRRR	1240	400	440	480
TRRT	1480	470	510	560
LRRL	1480	460	500	550
TTTT	1720	540	580	640
LLLL*	1720	520	560	620
RRRS	1360	420	460	510
RRRH	1360	430	470	520

*) Weight data applies to design with circuit-breaker type 2

Standards

8DJH switchgear complies with the relevant standards and specifications applicable at the time of type tests.

In accordance with the harmonization agreement reached by the countries of the European Union, their national specifications conform to the IEC standard.

Type of service location

8DJH switchgear can be used as indoor installation according to IEC/EN 61936 (Power Installations exceeding AC 1 kV) and VDE 0101.

- Outside lockable electrical service locations at places which are not accessible to the public. Enclosures of switchgear can only be removed with tools.
- Inside lockable electrical service locations. A lockable electrical service location is a place outdoors or indoors that is reserved exclusively for housing electrical equipment and which is kept under lock and key. Access is restricted to authorized personnel and persons who have been properly instructed in electrical engineering. Untrained or unskilled persons may only enter under the supervision of authorized personnel or properly instructed persons.

Terms

"Make-proof earthing switches" are earthing switches with short-circuit making capacity according to IEC/EN 62271-102 and VDE 0671-102.

Dielectric strength

- The dielectric strength is verified by testing the switchgear with rated values of short-duration power-frequency withstand voltage and lightning impulse withstand voltage according to IEC/EN 62271-1 / VDE 0671-1.
- The rated values are referred to sea level and to normal atmospheric conditions (1013 hPa, 20 °C, 11 g/m³ humidity according to IEC/EN 60071 and VDE 0111).
- The dielectric strength decreases with increasing altitude. For site altitudes above 1000 m (above sea level) the standards do not provide any guidelines for the insulation rating, but leave this to the scope of special agreements.

All parts housed inside the switchgear vessel which are subjected to high voltage are SF₆-insulated against the earthed enclosure.

The gas insulation at a relative gas pressure of 50 kPa (= 500 hPa) permits switchgear installation at any desired altitude above sea level without the dielectric strength being adversely affected. This also applies to the cable connection when using screened cable T-plugs or cable elbow plugs.

A decrease (reduction) of the dielectric strength with increasing site altitude must be considered for panels with HV HRC fuses as well as for air-insulated metering panels and a site altitude above 1000 m (above sea level). A higher insulation level must be selected, which results from the multiplication of the rated insulation level for 0 to 1000 m with the altitude correction factor K_a .

Overview of standards (July 2009)

		IEC/EN standard	VDE standard
Switchgear	8DJH	IEC/EN 62271-1	VDE 0671-1
		IEC/EN 62271-200	VDE 0671-200
Devices	Circuit-breakers	IEC/EN 62271-100	VDE 0671-100
	Disconnectors and earthing switches	IEC/EN 62271-102	VDE 0671-102
	Switch-disconnectors	IEC/EN 60265-1	VDE 0670-301
	Switch-disconnector/fuse combination	IEC/EN 62271-105	VDE 0671-105
	HV HRC fuses	IEC/EN 60282-1	VDE 0670-4
	Voltage detecting systems	IEC/EN 61243-5	VDE 0682-415
Degree of protection	–	IEC/EN 60529	VDE 0470-1
Insulation	–	IEC/EN 60071	VDE 0111
Instrument transformers	Current transformers	IEC/EN 60044-1	VDE 0414-1
	Voltage transformers	IEC/EN 60044-2	VDE 0414-2
Installation, erection	–	IEC 61936-1 HD 637-S1	VDE 0101

Altitude correction factor K_a for panels with HV HRC fuses or for metering panels type M

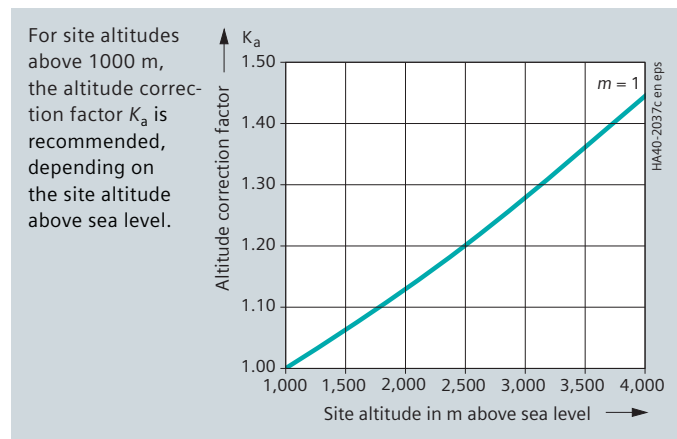

Curve $m = 1$ for rated short-duration power-frequency withstand voltage and rated lightning impulse withstand voltage according to IEC/EN 62 271-1 / VDE 0671-1.

Example:

3000 m site altitude above sea level
17.5 kV switchgear rated voltage,
95 kV rated lightning impulse withstand voltage

Rated lightning impulse withstand voltage to be selected $95 \text{ kV} \cdot 1.28 = 122 \text{ kV}$

Result:

According to the above table, a switchgear for a rated voltage of 24 kV with a rated lightning impulse withstand voltage of 125 kV is to be selected.

Standards

Standards, specifications, guidelines

Current carrying capacity

- According to IEC / EN 62271-200 / VDE 0671-200 or IEC / EN 62271-1 / VDE 0671-1, the rated normal current refers to the following ambient air temperatures:
 - Maximum of 24-hour mean + 35 °C
 - Maximum + 40 °C
- The current carrying capacity of the panels and busbars depends on the ambient air temperature outside the enclosure.

Appearance of internal faults

In gas-insulated switchgear 8DJH, faults leading to internal arcing are widely excluded by the construction by the following measures:

- Use of gas-filled switchgear compartments
- Use of suitable switching devices such as three-position switches with make-proof earthing switch
- Logical mechanical interlocks
- Use of metal-coated or metal-enclosed voltage transformers and three-phase current transformers as ring-core current transformers
- There are no effects due to external influences, such as
 - Pollution layers
 - Humidity
 - Small animals and foreign objects
- Maloperation is practically excluded due to logical arrangement of operating elements
- Short-circuit-proof feeder earthing by means of the three-position switch-disconnector.

In the event of an arc fault at the cable connection or in the unlikely case inside the switchgear vessel, pressure relief is effected downwards into the cable basement.

For the use in substation buildings without internal arcing test, such as "old substations", the switchgear can be designed with a modified pressure relief system with absorbers (option).

As a "special cooling system", this maintenance-free pressure absorber system reduces the pressure-dependent and thermal effects of internal arcing in switchgear vessels and cable compartments, and thus protects people and buildings.

The closed system is suitable for both wall-standing and free-standing arrangement.

Internal arcing test (design option)

- Protection of operating personnel by means of tests for verifying the internal arc classification
- Internal arcing tests must be performed in accordance with IEC / EN 62271-200 / VDE 0671-200 for **IAC** (internal arc classification)
- Definition of criteria:
 - Criterion 1
Correctly secured doors and covers do not open, limited deformations are accepted

- Criterion 2
No fragmentation of the enclosure, no projection of small parts above 60 g
- Criterion 3
No holes in accessible sides up to a height of 2 m
- Criterion 4
No ignition of indicators due to hot gases
- Criterion 5
The enclosure remains connected to its earthing point.

Optionally, 8DJH switchgear can be designed with internal arc classification.

Aseismic capacity (option)

8DJH switchgear can be upgraded for regions at risk from earthquakes. For upgrading, earthquake qualification testing has been carried out in accordance with the following standards:

- IEC / EN 60068-3-3, 1993
- IEC / EN 60068-2-6, 2007
- IEEE 693-2005
- IABG TA13-TM-002 / 98 (guide).

Climate and environmental influences

8DJH switchgear is completely enclosed and insensitive to climatic influences.

- Climatic tests are fulfilled according to IEC / EN 60932 (Report)
- All medium-voltage devices (except for HV HRC fuses) are installed in a gas-tight, welded stainless-steel switchgear vessel which is filled with SF₆ gas
- Live parts outside the switchgear vessel are provided with single-pole enclosure
- At no point can creepage currents flow from high-voltage potentials to earth
- Operating mechanism parts which are functionally important are made of corrosion-resistant materials
- Bearings in the operating mechanism are designed as dry-type bearings and do not require lubrication.

Color of the panel front

Siemens standard (SN) 47030 G1, color no. 700 / light basic (similar to RAL 7047 / gray).

Protection against solid foreign objects, electric shock and water

8DJH switchgear fulfills according to the standards *)

IEC/EN 62271-1	VDE 0671-1
IEC/EN 62271-200	VDE 0671-200
IEC/EN 60529	DIN EN 60529

the following degrees of protection (for explanations, see opposite table):

Degree of protection	Type of protection
IP 2X	for switchgear enclosure
IP 3X	for switchgear enclosure (optional)
IP 65	for parts of the primary circuit under high voltage

Type of arrangement: Wall-standing arrangement

IEC/EN 60529

Type of protection	Degree of protection
<p>Protection against solid foreign objects Protected against solid foreign objects of 12.5 mm diameter and greater (the object probe, sphere of 12.5 mm diameter, shall not fully penetrate)</p> <p>Protection against access to hazardous parts Protected against access to hazardous parts with a finger (the jointed test finger of 12 mm diameter, 80 mm length, shall have adequate clearance from hazardous parts)</p> <p>Protection against water No definition</p>	IP 2 X
<p>Protection against solid foreign objects Protected against solid foreign objects of 2.5 mm diameter and greater (the object probe, sphere of 2.5 mm diameter, shall not penetrate at all)</p> <p>Protection against access to hazardous parts Protected against access to hazardous parts with a tool (the access probe, sphere of 2.5 mm diameter shall not penetrate)</p> <p>Protection against water No definition</p>	IP 3 X
<p>Protection against solid foreign objects Dust-tight (no ingress of dust)</p> <p>Protection against access to hazardous parts Protected against access to hazardous parts with a wire (the access probe of 1.0 mm diameter shall not penetrate)</p> <p>Protection against water Protected against water jets (water projected in jets against the enclosure from any direction shall have no harmful effects)</p>	IP 6 5

Responsible for

Technical contents:
Bernd Schüpferling
Siemens AG, Dept. E D MV 2 PPM
Erlangen

General editing:
Gabriele Pollok
Siemens AG, Dept. E CC MCC G
Erlangen

*) For standards, see page 73

Published by and copyright © 2009:
Siemens AG
Energy Sector
Freyeslebenstrasse 1
91058 Erlangen, Germany

Siemens AG
Energy Sector
Power Distribution Division
Medium Voltage
Postfach 3240
91050 Erlangen, Germany
www.siemens.com/medium-voltage-switchgear

For more information, please contact our
Customer Support Center.
Phone: +49 180 524 70 00
Fax: +49 180 524 24 71
(Charges depending on provider)
E-mail: support.energy@siemens.com

Order No. E50001-K1440-A211-A1-7600
Printed in Germany
Dispo 31606, c4bs 7475
KG 07.09 5.0 76 En
6101/15475 480174

Printed on elementary chlorine-free bleached paper.

All rights reserved.
If not stated otherwise on the individual pages of this
catalog, we reserve the right to include modifications,
especially regarding the stated values, dimensions and weights.
Drawings are not binding.
All product designations used are trademarks or product
names of Siemens AG or other suppliers.
If not stated otherwise, all dimensions in this
catalog are given in mm.

Subject to change without prior notice.
The information in this document contains general
descriptions of the technical options available, which
may not apply in all cases. The required technical
options should therefore be specified in the contract.